

# **A Framework for Implementing Cloud Based Enterprise Resource Planning (ERP) in the Transport Business Sector in Zimbabwe.**



**Maxwell Bindi (R104585C)**

# **A Framework for Implementing Cloud Based Enterprise Resource Planning (ERP) in the Transport Business Sector in Zimbabwe.**



**By**

**Maxwell Bindi**

**(R104585C)**

Submitted in partial fulfilment of the requirements for the degree of

**Master of Science in Information Systems Management**

Department of Computer Science and Information Systems in the

Faculty of Science and Technology at the

**Midlands State University**

**Gweru**

**May 2016**

Supervisor: **Mrs. A. Mutembedza**

Co-Supervisor: **Mr. M. Zhou**

## **ABSTRACT**

This study sought to develop a framework for the implementation of cloud based Enterprise Resource Planning (ERP) system in the transport business sector in Zimbabwe: A case of CMED (Pvt) Ltd. Information was gathered through interviews, questionnaire and case study approaches. The concept of cloud computing is not new in the transport business but it was used for telematics only not for integrated system like ERP. An Enterprise Resource Planning (ERP) system is an enterprise-wide software system that provides comprehensive functionality and allows integration of core business processes in organisations. Participants were selected from CMED (Pvt) Ltd different provinces dotted around the country. The results suggested that there is need to develop a framework for the implementation of cloud based ERP system in the transport business sector in Zimbabwe. There was evidence to suggest that top management involvement is key to the successful implementation of cloud based ERP system. Gaining trust and support from top management is very important as they are the once who avails resources for the successful implementation of the cloud based ERP. Data security is also a key issue in the implementation of cloud based ERP system. The proposed framework suggested that there are eight stages: present situation analysis, problem and business process detection, developing new process, information system incorporation, organizing system training, application, process improvement, and ERP system Delivery. There are also issues that must be addressed before moving the data into the cloud. These issues includes individual, corporate, strategic well as security issues. These issue have to be address at every stage for the implementation to be successful. The study recommended that for CMED (Pvt) Ltd to gain competitive advantage, it is vital to give enough time towards training of users, involve users from the beginning of the project, get top management trust and support, and allocate enough resources towards the problem and involved qualified people to be part of the project team to avoid loss of company resources. Cloud based ERP system promotes mobile computing, which is the ability to access resources from anywhere at any time. Future research can look at the storage capacity and cloud data encryption in conjunction with the proposed cloud based ERP implementation framework.

**Keywords:** ERP, Cloud Computing, Mobile Computing

## DECLARATION

I, Maxwell Bindi, hereby declare that I am the sole author of this thesis. I authorize the Midlands State University to lend this thesis to other institutions or individuals for the purpose of scholarly research.

Signature \_\_\_\_\_ Date \_\_\_\_\_

## **APPROVAL**

This dissertation entitled “A Framework for Implementing Cloud Based Enterprise Resource Planning (ERP) System in the Transport Business Sector in Zimbabwe” by Maxwell Bindi meets the regulations governing the award of the degree of Master of Science in Information Systems Management of the Midlands State University, and is approved for its contribution to knowledge and literary presentation.

.....

Supervisor’s Signature (Mrs. A. Mutembedza)

.....

Date

.....

Co-Supervisor’s Signature (Mr. M. Zhou)

.....

Date

## **ACKNOWLEDGEMENTS**

This research would not have been successful had it not been for the support I received from a great number of people, and I thus owe them a great deal of gratitude.

Much thanks and appreciations goes to the Almighty God above for the strength to keep me going despite a number of obstacles in my path. May Jah continue to guide and protect.

I would also like to acknowledge the unique role that my two supervisors Mr. M. Zhou and Mrs. A. Mutembedza, the lecturers at the Midlands State University, Department of Computer Science and Information Systems played. Your guidance, direction, comments and personal interest in my work was a great source of motivation which inspired me to work harder and put on the extra mile. They never tired and they open my mind to some of the things I never thought of and take for granted. More appreciation goes to the whole department of Computer Science and Information Systems at the Midlands State University for their insightful comments.

I would also like to acknowledge my family, friends and all who participated in this study for their support and encouragement that they gave me even when things were difficult. I say don't do this to me alone but to the rest of the family and friends. Thank you people, May the peace of the lord, which surpasses all understanding, guard your hearts and thoughts through Christ Jesus.

Lastly but not least, I would like to thanks my classmates for their encouragement. Once again I say Thank you.

## **DEDICATION**

I dedicate my dissertation work to my family and many friends. A special feeling of gratitude to my loving wife, Rutendo and wonderful son and daughter, Tamiranashe Godswill and Ruvarashe Blessing respectively, for being there for me throughout the entire Master of Information System Management program. Both of you have been my best cheerleaders.

## Table of Contents

ABSTRACT.....	i
DECLARATION .....	ii
APPROVAL .....	iii
ACKNOWLEDGEMENTS .....	iv
DEDICATION .....	v
LIST OF ACRONYMS .....	x
LIST OF FIGURES .....	xii
LIST OF TABLES .....	xiii
CHAPTER 1: INTRODUCTION .....	1
1.1 Introduction.....	1
1.2 Background of the Study .....	1
1.3 Problem Statement .....	2
1.4 Research Objectives.....	3
1.5 Research Questions.....	3
1.6 Research Methodology .....	3
1.7 Significance of the Study .....	6
1.8 Assumptions, Scope, and Limitations/Delimitations .....	7
<b>1.8.1 Assumptions</b> .....	7
<b>1.8.2 Scope of the Study</b> .....	7
<b>1.8.3 Limitations of the Study</b> .....	7
<b>1.8.4 Delimitations of the Study</b> .....	8
1.9 Proposed Contribution .....	8
1.10 Conclusion .....	8
CHAPTER 2: LITERATURE REVIEW .....	10
2.1 Introduction.....	10
<b>2.1.1 Context of Commercialization</b> .....	11
<b>2.1.2 CMED (Pvt) Ltd Today</b> .....	11
<b>2.1.3 Cloud Based Enterprise Resource Planning (ERP)</b> .....	11
2.2 Enterprise Resource Planning (ERP) .....	12
2.3 ERP implementation .....	13
<b>2.3.1 Benefits of ERP implementation</b> .....	14



<b>3.3.2 Limitations of ERP system</b> .....	16
2.4 Cloud Computing .....	17
2.5 Security concerns for cloud based ERP implementation .....	18
2.6 Infrastructure Considerations in ERP System Implementation.....	19
2.7 Role of leadership in ERP Systems Implementation .....	22
<b>2.7.1 Change management in ERP systems</b> .....	22
<b>2.7.2 Impact of change</b> .....	22
2.8 Challenges in Implementing ERP .....	24
<b>2.8.1 Framework for ERP implementation</b> .....	27
2.9 Conclusion .....	30
CHAPTER 3: RESEARCH METHODOLOGY .....	31
3.1 Introduction.....	31
3.2 Research Methodology .....	32
3.3 Qualitative Research .....	32
3.4 Case Study .....	33
3.5 Research Strategy.....	33
3.6 Strategy for Sampling .....	34
<b>3.6.1 Purposive strategy for sampling</b> .....	34
<b>3.6.2 Targeted populace</b> .....	34
<b>3.7.3 Sample Scope</b> .....	35
3.7 Methods of Collecting Data .....	35
<b>3.7.1 Primary Data</b> .....	35
<b>3.7.2 Secondary</b> .....	35
<b>3.7.3 Questionnaires</b> .....	36
<b>3.7.4 How the questionnaires were distributed</b> .....	36
3.8 Findings' Reliability and Validity.....	36
<b>3.8.1 Findings' Reliability</b> .....	36
<b>3.8.2 Validity</b> .....	37
3.9 Analysis of the Data.....	37
<b>3.9.1 Narration</b> .....	37
<b>3.9.2 Coding</b> .....	37
<b>3.9.3 Data Interpretation</b> .....	37

<b>3.9.4 Data Confirmation</b> .....	38
<b>3.9.5 Data Presentation</b> .....	38
3.10 Ethical Consideration .....	38
<b>3.10.1 Obtain Consent</b> .....	38
<b>3.10.2 Privacy and Confidentiality</b> .....	38
<b>3.10.3 Deception</b> .....	38
3.11 Conclusion .....	39
CHAPTER 4: DATA PRESENTATION, ANALYSIS AND DISCUSSION .....	40
4.1 Introduction .....	40
4.2 Background of Survey Participants .....	40
<b>4.2.1 Participants' Gender</b> .....	41
<b>4.2.2 Participants' Age</b> .....	42
<b>4.2.3 Employment Type</b> .....	43
4.3 Findings from Questionnaires and Interviews .....	44
<b>4.3.1 Enterprise Resource Planning Issues</b> .....	44
<b>4.3.1.1 Participants' Experience with the ERP systems.</b> .....	45
<b>4.3.1.2 ERP system modules</b> .....	46
<b>4.3.1.3 What do you understand by the term ERP system?</b> .....	46
<b>4.3.1.4 What is your view on cloud based ERP system as an alternative to On-Premises ERP system?</b> .....	46
<b>4.3.1.5 What impact do you think cloud based ERP system will have on the convenience in providing services to the customers?</b> .....	46
<b>4.3.1.6 How else do you think On-Premises system could be improved?</b> .....	47
<b>4.3.1.7 What is your take on the use of ERP system in CMED (Pvt) Ltd currently and what are the benefits?</b> .....	47
<b>4.3.1.8 Can you highlight what you think were the reasons for ERP system introduction?</b> .....	47
<b>4.3.1.9 Why do you think the implementation of ERP system was a right decision or it is a regret?</b> .....	47
<b>4.3.1.10 How do you think ERP system has progressed and can you highlight the factors that leads to its success?</b> .....	48
<b>4.3.1.11 Can you list the problems and challenges met during ERP system implementation and their effects to the company?</b> .....	48
<b>4.3.1.12 What measures should be taken to address the challenges? In addressing these challenges who should take a leading role?</b> .....	48

4.3.2 Training of Employees.....	49
4.3.2.1 What type(s) of training did you receive?.....	49
4.3.2.2 If you receive training, how long does it take you to master the ERP system? .....	50
4.3.3 Security issues associated with ERP implementation .....	51
4.3.3.1 What type of security problems do you experience with the ERP system? .....	51
4.3.3.2 How often do you change your password? .....	51
4.3.3.3 What are the required combinations for the password? .....	51
4.4 Discussion of Questionnaires and Interview Results .....	51
4.4.1 Research Participants .....	52
4.4.2 Opportunities.....	52
4.4.3 Challenges.....	52
4.5 Conclusion .....	53
CHAPTER 5: CONCLUSION, RECOMMENDATIONS AND FUTURE WORK.....	54
5.1 Introduction.....	54
5.2 Re-statement of the research problem and objectives .....	54
5.3 Answering the major question .....	54
<b>5.3.1 Proposed Cloud Based ERP Framework for transport business sector .....</b>	<b>54</b>
5.4 Recommendations.....	58
5.5 Suggestion for Future Research .....	59
5.6 Conclusion .....	59
APPENDICES .....	66

## **LIST OF ACRONYMS**

BAT	British American Tobacco
CPO	Chief Project Officer
CRM	Customer Relationship Management
EDI	Electronic Data Transfer
ERP	Enterprise Resource Planning
FGI	Finished Goods Inventory
GMB	Grain Marketing Board
HCCL	Hwange Colliery Company Limited
HRM	Human Resources Management
ICT	Information Communication Technology
IT	Information Technology
MIS	Management Information System
MPC	Manufacturing Planning and Control
MRP	Material Requirement Planning
NIST	National Institution of Standards and Technology
NSSA	National Social Security Authority
PSC	Public Service Commission
SaaS	Software as a Service
SADC	Southern African Development Countries
SAP	System, Application and Product

SEA	Southern Eastern Africa
WIP	Work In Progress
Y2K	Year Two Thousand
ZESA	Zimbabwe Electricity Supply Authority
ZMDC	Zimbabwe Mineral Development Corporation

## LIST OF FIGURES

Figure 1.1:	Research Onion	.....9
Figure 2.1:	ERP Implementation Stages	.....16
Figure 2.2:	ERP on Cloud	.....20
Figure 2.3:	ERP Implementation Framework	.....29
Figure 2.4:	Cloud mobile ERP System Components	.....30
Figure 2.5:	Cloud ERP evaluation Framework	.....31
Figure 4.1:	participants' Gender	.....43
Figure 4.2:	Participants' Age	.....45
Figure 4.3:	Employment Type	.....46
Figure 4.4:	Participants' Experience with ERP System	.....47
Figure 4.5:	Types of Training	.....51
Figure 4.6:	Training Period	.....52
Figure 5.1:	Proposed Cloud Based ERP Framework	.....57

## LIST OF TABLES

Table 4.1:	Participants' Gender .....	43
Table 4.2:	Participants' Age .....	44
Table 4.3:	Employment Type .....	45
Table 4.4:	Period of ERP System Use by Participants .....	47
Table 4.5:	Types of Training .....	51
Table 4.6:	Training Period .....	52
Table 5.1	Recommendations from Findings .....	60

**LIST OF APPENDICE**

Appendix A: Interview Guide ..... 68

Appendix B: Sample Questionnaire .....69



# **CHAPTER 1: INTRODUCTION**

## **1.1 Introduction**

The purpose of this research is to develop a framework that can be used in the implementation of cloud based Enterprise Resource Planning (ERP) system in the transport business sector. Organisations always spend significant amounts of money on Information Systems. If they spend devoid of recognizing the current value of support and upcoming restrictions, they cannot gain competitive advantage in a rapidly changing business world (Tansley, Newell, Williams, 2007). Cloud based Enterprise Resource Planning (ERP) is an Information System in which one should invest intelligently. Most of the large-scale organisations spend large amounts on cloud based ERP, but unfortunately, many of them utilize it just for administrative purposes rather than for effective and efficient allocation of resources. After spending considerable amounts, if cloud based ERP is used only for administrative work, it will not be effective. This study aims to come up with the conceptual framework for the implementation of cloud based ERP in the transport industry in Zimbabwe, that will go a long way giving management an understanding of how processes are taking place in the ERP as well as the security of the data in the cloud. Most of the framework which are there are not specific to the transport sector due to the fact that transport is unique in how its transactions are being handled. Also the problem statement is the lack of proper framework for the implementation of cloud based ERP system in the transport business sector in Zimbabwe. This chapter will help to introduce the research and give a brief outline about the research.

## **1.2 Background of the Study**

Since 1960s and 1970s, which are the years that mark the beginning of software manufacturing, many organisations made use of open inventory systems that were known as Material Requirement Planning (MRP) (Orlicky and Plossl, 1994). This allows managers to make estimates on raw materials and production costs. To handle basic functions of MRP, computers remained mandatory, and to create orders and purchases among suppliers and consumers, Electronic Data Interchange (EDI) was required to save time and the budget of printing materials. During late 1990s, the Year Two Thousand (Y2K) difficulty caused enterprises to transfer to Enterprise Resource Planning (ERP) methods (Tsai, Hwang and Hsu, 2010). ERP help

organisations to regulate their budget and strategize in an effective and proficient way. ERP systems consist of fundamental databases, procedure modules and regulator systems. With ERP methods various organisational functions can be done at the same time, such as human capitals, finance, sales and marketing, then change management. All are combined in single scheme and can be accessed anywhere in the organisation. The study is worth doing because all the previous researchers were concentrating on small to medium enterprises and manufacturing industry but no one has tried to do a framework for implementation of cloud base ERP system in the transport sector in Zimbabwe. Most of the studies that have been done were specific to one type of ERP system for example Systems, Applications and Products (SAP) implementation in some sectors not even specific to transport sector in Zimbabwe.

### **1.3 Problem Statement**

ERP systems are beginning to appear in many corporates of developing countries like Zimbabwe. Little research has been conducted to come up with the framework for cloud based ERP system implementation in the transport business sector in Zimbabwe. For example Akkermans and van Helden (2002) and Monk and Wagner (2006) observes that a typical ERP implementation initiative takes anywhere between one to three years and typical amounts are in tens or hundreds of millions of United States dollars. So there is need to have a proper framework so that top management will make an informed decision before committing company funds in a project that may fail if not properly implemented.

Despite numerous benefits that can be achieved through the use of cloud based Enterprise Resource Planning (ERP) in transport sector, it is still underutilized (Adam and Doherty 2000). ERP will bring hope in the order fulfillment process in transport sector in Zimbabwe, by improving the way CMED takes customer order and processes it into invoice and revenue. In Zimbabwe, transport industry focuses on vehicle tracking, thereby ignoring other functions, for example, fleet management, fuel management, and vehicle recovery and maintenance. In most instances transport sector organisations keep separate spreadsheets with different vehicle information, and no integration at all, cloud based ERP will integrate all the mentioned functions into one integrated system.

## **1.4 Research Objectives**

The main objective is to develop the framework for the implementation of operational cloud based Enterprise Resource Planning (ERP) for transport industry in Zimbabwe. The sub objectives are as follows:

1. To find out the security requirements for the implementation of cloud based ERP in the transport industry in Zimbabwe.
2. To find out the IT infrastructure required for the successful implementation of cloud based ERP in the transport business sector in Zimbabwe.
3. To identify opportunities for cloud based ERP to improve business functional performance in the transport business sector in Zimbabwe.
4. To find ways to overcome the potential risks associated with moving ERP from server based to cloud based ERP in the transport business sector in Zimbabwe.

## **1.5 Research Questions**

The primary research question is how to come up with the framework for the implementation of cloud based ERP system in transport business sector in Zimbabwe? The sub questions are as follows:

- What are the security requirements for the implementation of cloud based ERP in the transport business in Zimbabwe?
- What are the IT infrastructure requirements for the effective implementation of cloud based ERP in the transport business in Zimbabwe?
- What are the business opportunities and challenges brought by cloud based ERP in the transport sector in Zimbabwe?
- What are the role of leadership in ensuring effective implementation of cloud based ERP systems in the transport business sector in Zimbabwe?

## **1.6 Research Methodology**

The research discusses all feasible characteristics associated with Cloud Based ERP systems through a comprehensive comparisons of ERP before and after migrating to cloud computing

environment. The purpose of this comparison is to show the idea of ERP is significant whilst running on cloud platform as compared to On-Premises ERP system. Another objective is to develop a generic framework for cloud based ERP favor of transport industry sector in Zimbabwe. To fulfill the objectives, previous work in ERP is analyzed and issues are identified. Cloud based ERP is investigated in the light of cloud characteristics. Research onion is used to carry out the investigations. An elegant framework is proposed in order to handle industry functionality and solution integration challenges. Common applications such as accounts, CRM modules, MIS systems, Invoice, HRM systems, and CMS will be operated under Software as a Service (SaaS) to deliver the framework.

**Figure 1.1: Research onion**

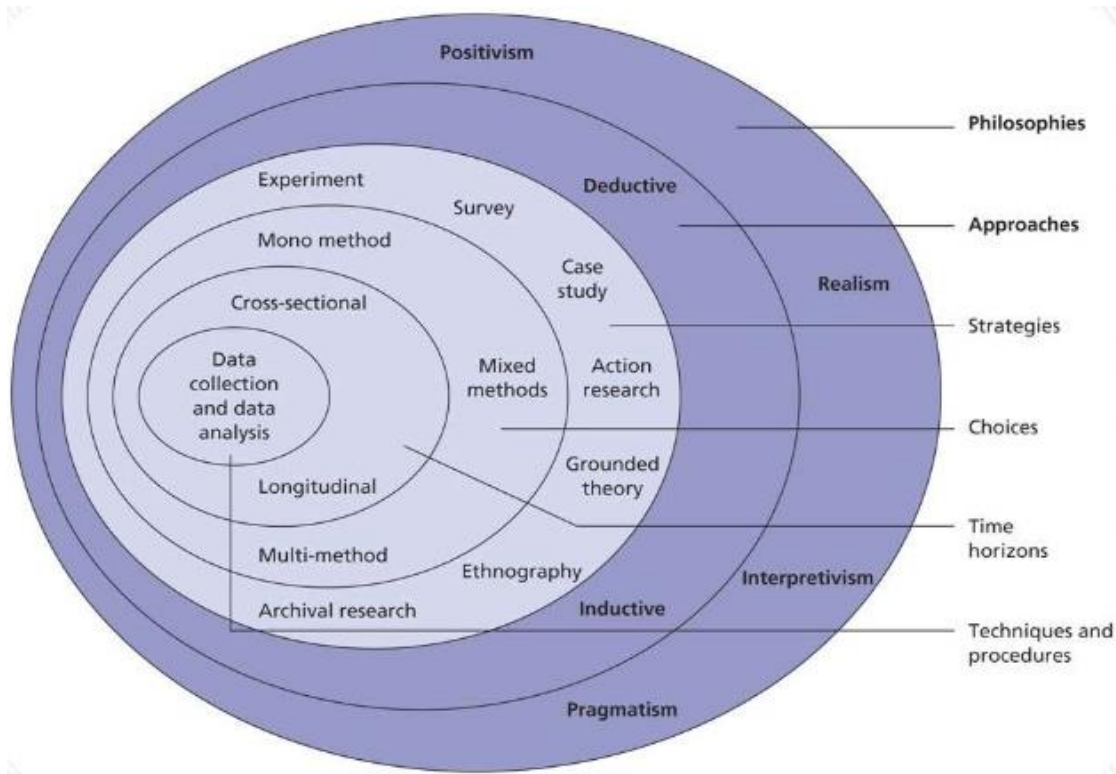

*Source: Research Process Onion, Saunders et.al (2009).*

The concept of methodological framework refers to the theory of how research should be undertaken including the theoretical assumption upon which the research is based and the implications of these for the methods adopted (Saunders et al, 2009). According to Saunders and others (2009) the research onion depicted above (Figure 1.1) describes the steps that should be

adopted in conducting the study. The research onion is made up of six layers: research philosophy, research approaches, strategy, choices, time horizon, techniques and data collection.

This research shall adapt an interpretivism approach as opposed to either positivism or realism. Looking back at the purpose and concept of this study, the researcher must explore, analyze, and make recommendation to CMED (Pvt) Ltd on the best framework to use in implementing cloud based ERP. This demonstrated uniqueness and complexity nature of this research (Saunders et.al, 2009). The research must not be governed or restricted by a set of defined “laws” as promoted by positivism philosophy. In the world of management research, best working practices for organisation A does not necessarily fits organisation B given the similarity of both organization’s size and activities across the value chain. Therefore it is vital to make an extension exploration and take into account all factors present, weigh them accordingly and formulate and recommend a best fit framework that fits well in all transport sector businesses.

Given the aim of this research, deductive approach shall be considered as data gathered and analyzes from all proposed origin and shall be used to formulate necessary recommendations to CMED (Pvt) Ltd.

Hence the research strategies proposed shall involve a case study and due to inevitable time limitation, the research shall be that of cross sectional time frame. The research must bring out rich and expensive understanding of information gathered (interviews with leaders who are the essence of the organisation and information gathered from questionnaires from different transport business sectors categories which includes fuel and lubricates, customer care, billing, fleet management, asset management, and cross boarder bus services) and this in turn shall ease the process of investigation and better recommendation will be offered. The fast changing environment that encompasses organisations today must ensure the research allows room for flexibility and adoptability to change and able to explore all available options. (Yin, 2003).

In this research names of participants will be kept confidential. Participants will be enlightened concerning the nature of the research and how they will participate in the research. Response from the participants will be voluntary and participants can withdraw from the research if need be. The participants will in no way be subjected to embarrassment, stress, discomfort, harm and pain during the research process. A formal agreement will be reached between the researcher and

participants in this case CMED (Pvt) Ltd staff (employees and management). There is also need to consider the confidentiality of resources availed to the researcher. It must be handled with utmost care and high level of confidentiality

### **1.7 Significance of the Study**

This research proposal is nominated for benefits derived from implementation of the cloud based ERP solution in transport industry. The research underlines the benefits derived from cloud based ERP solution to take the industry trail better (Shkurskii and Sabel'nikova, 2011). The cloud based ERP helps the employees to serve their time as it does not need any supplementary hardware to set up, and alongside with this, it also cuts out the additional expense of rolling out to the numerous centers (Vimalkumar, 2012). Cloud based ERP solution has the effect on the company's overall result; therefore it is recommended to take advice of all the stakeholders before its implementation.

The emphasis of the research is on proper implementation of cloud based ERP in transport industry. Although there are many transport companies in Zimbabwe who provides transport services to the general public, this research will focus on CMED (Pvt) Ltd because it covers all the functions that are found in transport industry, thereby will provide a better representation of the transport sector. CMED (Pvt) Ltd operations includes: vehicle and equipment hire, cross border bus services , fuel and lubricants sales, vehicle and equipment maintenance, driver training and re-testing, vehicle and equipment evaluation, Reconditioning, and Government Authority driver and training and recently airport tax and shuttle services.

It is the researcher's belief that the framework will be able to be adopted by CMED (Pvt) Ltd without challenges. The study is worthy carrying out as it intent to come up with a standard framework that can be used in the implementation of cloud based ERP in the transport business sector in Zimbabwe. The paper will complement to the body of knowledge on ERP systems and Information Communication and Technology (ICT) in the transport business sector. The Systems Administrators, academics, transporters, and IT specialists are expected to use this document. A framework to implementation of cloud based ERP system in the transport business sector in Zimbabwe will be established for the advantage of transporters who implement cloud based ERP in the sector.

## **1.8 Assumptions, Scope, and Limitations/Delimitations**

This unit places of interest on the assumptions, scope and limitations of the research paper.

### **1.8.1 Assumptions**

Most transport companies are making use of ERP technologies as distribution networks to deal conveniently with users. With this fast changing in technology the needs of users are fast changing, which require them to transact while they are travelling or on vacations. This forces transport companies to adopt cloud based ERP without failure.

The selected sample will be demonstrative of the population. The selected sample comprise a lean of employees who interact with systems and are affected by systems on a daily bases, such that, the discoveries can be secondhand to simplify how transport companies can tactically transpose themselves.

All the participants in the research should offer all the information necessary which is a true replication of what is happening on the ground. All the ethical issues that can stop respondents giving correct information which include anonymity, confidential information and privacy will be considered in the research. This will eliminate any panic in giving evidence by the respondents.

### **1.8.2 Scope of the Study**

For the purpose of this paper, the researcher intent to target CMED (Pvt) Ltd Head office and Regional offices within Zimbabwe. The research involves CMED (Pvt) Ltd's ERP system implementation, whether it is properly implemented or not and what needs to be done in order to properly implement cloud based ERP in the transport industry.

### **1.8.3 Limitations of the Study**

There are constraints to this research. The main constraint is that of time. Ample time is required to gather data, but managers and workshop employees have skintight programs to address each and every single day so it will be a challenge to collect data from them. Furthermore, the total number of participating members is likely to be smaller than expected since it will be

challenging to get appointments due to the tight program of managers and workshop staff. CMED (Pvt) Ltd deals with sensitive information, so there is the concern of privacy as a highest importance, therefore access to delicate material might become a huge restraint of this study. Physical sites are extra constraints since regional offices are established in several regions which becomes challenging to visit all the staff in regional offices across the country.

#### **1.8.4 Delimitations of the Study**

This study intend to cover road transport sector by taking CMED (Pvt) Ltd branches all over Zimbabwe. It implies that the assessment will focus on operations conferred to road transport (CMED (Pvt) Ltd) in as much as transport business is concerned. Beyond the scope of the research are issues that encompass other transport sectors like sea, rail, and air transport.

#### **1.9 Proposed Contribution**

The study is worthy carrying out as it intends to come up with a standard framework that can be used in the implementation of cloud based ERP in the transport business sector in Zimbabwe. The research will enhance the body of knowledge in Information Communication and Technology (ICT) in the transport business sector. The transporters and Information Technology professionals are going to use this document. A framework for implementation of cloud based ERP in the transport business sector in Zimbabwe is going to be established for the good of transporters who need to implement cloud based ERP in the sector.

#### **1.10 Conclusion**

The overall study will be presented in five chapters, with chapter one containing the background to the study, statement of the problem, objectives, research questions, justification and other introductory information.

Chapter two will contain the literature review and the theoretical framework. This chapter will deal with the relevant contribution of other scholars.

Chapter three will be composed of the methods to be used in data collection a well as the sampling, analysis and presentation procedures.



Chapter four serves to demonstrate the research findings or the outcome of the study.

Chapter five will be the last chapter carrying the overall conclusion of the study as well as any recommendations offered to address the observed scenarios.

## **CHAPTER 2: LITERATURE REVIEW**

### **2.1 Introduction**

The purpose of this research is to come up with the framework that can be used in the implementation of cloud based ERP system in the transport business sector. Chapter 1 introduced the research study by stating the research question, the aims of the study, and its importance. It is in this chapter where available articles, books, journals and the web are being reviewed in the domain of ERP implementation. The chapter is also going to look at some of the frameworks for implementing cloud based ERP systems, that have previously developed and prospects that can be used to stay viable in the transport business sector and build a significant business situation for this research. The tenacity of the literature review is to recognize and review limited number of relevant research studies, and to explore and learn from theories that inform the current study. In this part of the research, present works about Enterprise Resource Planning adaptation was revised so as to get a better understanding on effect the framework have on implementation of ERP systems on various angles.

CMED (Pvt) Ltd is a state owned company set up by government to provide transport hire services and procure vehicles on its behalf. Cabinet approved the commercialization of CMED and its transformation into a private limited liability company, wholly owned by government in 1997. Subsequent to this, the Ministry of Transport and Communication commissioned a study to come up with a commercialization strategy, which was implemented in 2001 following the promulgation of the CMED (Commercialization) Act by parliament in 2000. With the enabling Act in place, CMED was registered under the Companies Act in 2001. In August the same year the Minister of Transport and Communication appointed a Board of Directors to oversee the restructuring process and provide policy guidance on the management and running of CMED (Private) limited along commercial lines.

CMED (Pvt) Ltd is a successor company to the former Central Mechanical Equipment Department which was operating as a Government department. Currently CMED (Pvt) Ltd is registered as a Private Limited Company with the mandate of turning the parastatal into viable commercial entities which will exploit both Government Departments and the Private Sector

market. By commercializing CMED (Pvt) Ltd it was hoped that this would enable the company to move with the same pace as its rivals hence enabling it to maintain its competitive advantage.

### **2.1.1 Context of Commercialization**

The core business of the public service is to act as an administrative arm of Government, assisting in the formulation of national policies and plans, monitoring and enforcing compliance to the relevant statutes. In this context the business of vehicle hire, maintenance and repair was considered to be a non-core Government function and hence had to be commercialized. In summary, this explains the rationale behind CMED's commercialization. The objectives of commercializing Government Departments are to: -

Allow for efficient and effective management in the commercialized entities by granting them an autonomous status. Commercialization gave CMED free liberty in their decision making capacity, giving them authority to make policy decisions that previously would have been made at ministry level and makes the chief executives of those entities fully accountable for achieving service delivery without resorting to Government support and subventions. Decision-making and accountability is devolved to management boards and there will be reduced direct supervision of the commercialized entities from parent ministries.

### **2.1.2 CMED (Pvt) Ltd Today**

Currently CMED (Pvt) Ltd is a parastatal in the transport industry with 13 branches in Zimbabwe and its Head office is in Harare where most of the activities and functions are centralized and controlled. The 13 branches are Head Office, Harare (Workington), Bulawayo, V.I.P, Gweru, Mutare, Bindura, Marondera, Chinhoyi, Masvingo, Gwanda, Mt Hampden, Chikurubi, Fuels (Petroleum Oils and Lubricants (POL)) and Easy go.

### **2.1.3 Cloud Based Enterprise Resource Planning (ERP)**

There is need to understand: what is cloud computing? There is a thin line between cloud base ERP and cloud computing. The generally accepted definition of Cloud computing comes from the National Institute of Standards and Technology (NIST). The NIST definition runs to several hundred words but essentially says that: "Cloud Computing is a model for enabling convenient,

on-demand network access to a shared pool of configurable computing resources (for example, networks, servers, storage, applications and services) that can be rapidly provisioned and released with minimum management effort of service provider interactions.” What this means in plain terms is the ability for end users to utilize parts of bulk resources and that these resources can be acquired quickly and easily. Cloud computing is the practice of using a network of remote servers hosted on the internet to access hardware, software and other services on –demand, anywhere, anytime. Cloud based Enterprise Resource Planning is the technology that can be used to access organisations resources from anywhere, and anytime (real time) and update the database as the transaction is taking place.

The current economic resuscitations in government operations require government agencies to become innovative and transparent in all their operations, so that it will be easy to attract direct investment from international investors. They need to reconsider their business models and to be operationally effective to address the present challenges and increase profitability. This section will cover the background of the study to show the position that created awareness in the research, the problem statement, research questions and objectives, and the justification of the study with research integrity/ethics in mind.

Cloud computing comes in three forms: public clouds, private clouds, and hybrids clouds. Depending on the type of data you are work on, you will want to compare public, private, and hybrid clouds in terms of the different levels of security and management required (Morris, 2016).

Therefore cloud based ERP actually saves our extra time which can be lost at the time of installing hardware. Cloud based ERP also saves on money as it cuts out the additional budget which is associated with these roll out. Cloud based ERP acquire less users when one’s business grows as it is really very easy to handle and it also give flexibility to the users.

## **2.2 Enterprise Resource Planning (ERP)**

Enterprise Resource Planning (ERP) is defined as: “An enterprise-wide set of management tool that balances demand and supply, containing the ability to link customers and suppliers into a complete supply chain, employing proven business processes for decision-making and providing

high degree of cross-functional integration among sales, marketing, manufacturing, operations, logistics, purchasing, finance, new product development, and human resources, thereby enabling people to run their business with high level of customer service and productivity, and simultaneously lower costs and inventories and providing the foundation for effective e-commerce “(Knemzar and Wallace, 2011).

As ERP systems appears to be at the center of all the activities of all the companies more and more firms carry out ERP systems implementation to improve relevance in their business sector. Leadership of these ERP systems and the way people are impacted in the organisations have been relevant. More emphasis was placed on “soft side” of tasks, that is, the people aspect as well as difficulties which normally met in implementation of those systems. Jorgensen et al (2009) alluded that for most organisations, formal change management has not yet permeated business or project operations to a significant degree. Today’s change management, if explicitly performed at all, often occurs in the form of improvised solutions, but a consistent and structured change management approach yielded tangible benefits for most organisations.

*Lee and Lee* (2001) says, an ERP system is more than a software package to be custom-made to a firm, but a firms infrastructure that touches how people work and imposes its own logic on a company’s strategy, organisation, and culture. The carrying-out of ERP systems management has stood as a broadly studied subject matter for several decades and several researches, including the work of Lee and Lee (2001) revealed that the carrying out of such a system is highly complex.

### **2.3 ERP implementation**

ERP implementation is an important business decision that requires business entities to work together and make this decision as a team not as individuals. ERP projects adoption offer an amount of advantages to organisations such as, proper accounting, recruitment, supply chain management and sales and marketing. Consequently, companies and Information Technology leaders should know identify when the time is right to acquire, further develop ERP systems. ERP system implementations are often said to be more organizational focused than technological focused, and it is more around people than around processes and technology. This indicates that taking the implementation of ERP system from an organizational perception will contribute to a wider appreciative of the implementation procedure. Necessary skills and capabilities are not the

same as before the implementation of the ERP system, which entails that education and information are remarkable issues to elaborate.

The ERP system implementation can cause organisational changes in terms of power and culture. Power and culture is a part of the implementation context and an implementation cannot be fully understood detached from the context from which the system occurred. ERP implementation can change the processes and the organisation or can lead to totally new business. This entails that

of attaining an understanding of the intricacy. The ERP implementation stages can be categorized into five major stages as viewed for SAP ERP implementation of a multinational company venturing in the manufacture of basic commodities and summaries in Figure 2.1 below:

**Figure 2.1: ERP implementation Stages**

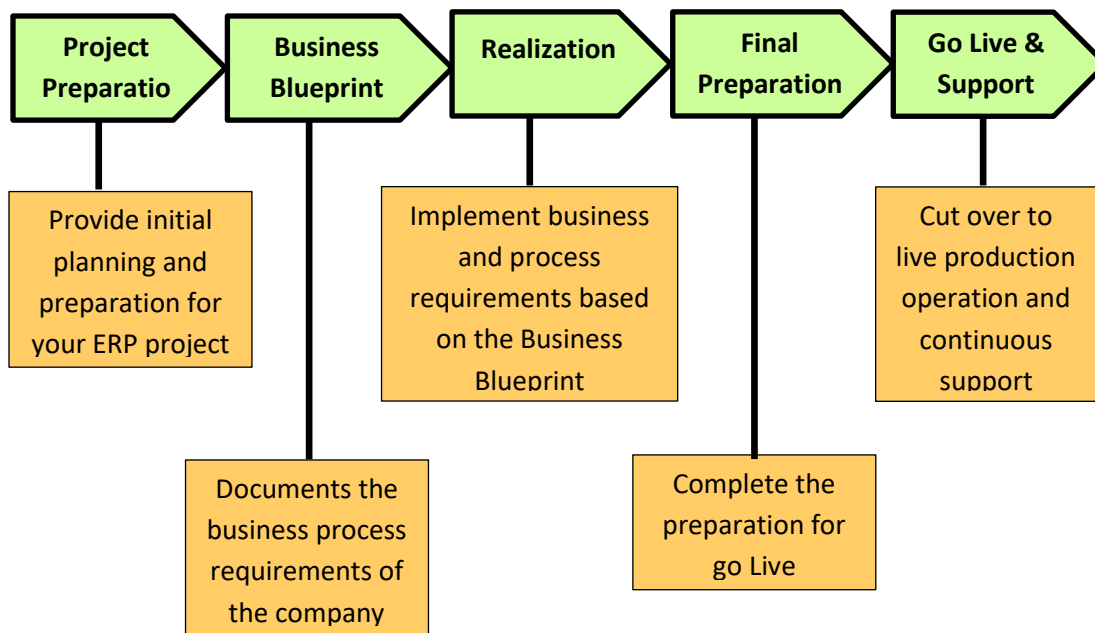

*Source: CIE42 Proceedings, 16-18 July 2012, Cape Town, South Africa*

### **2.3.1 Benefits of ERP implementation**

“What are the benefits of ERP systems?” is the question that appears in any discussion on implementation of ERP system. The use of ERP system by the transport industry can be divided into six categories which are as follows:

1. Human Resources:

- Improve employee performance management.
  - Improve learning, training and development.
  - Facilitate business learning.
  - Better resource management.
  - Improve decision making capability.
  - Improve the interaction between business units.
  - Centralize the administrative activities.
  - Greater ability to deploy new information systems functionality.
  - Improved the performance of the transport industry.
  - Improve the information accuracy/speed/quality/ and availability.
  - General information integration.
  - Talent management analytics.
  - Real time data access across multiple sites.
2. Operations and logistics (Telematics and Auto-billing).
- Generate product differentiation.
  - Increase the integration between organisation with customers and suppliers in a long term plan.
  - Better production planning scheduling.
  - Improve resource utilization.
  - Lower inventory level.
  - Improve order management/order cycle.
  - Reduce quality costs.
  - Reduce cycle time of production.
  - Reduction of lead time.
  - Reduce direct operating costs.
  - Reduce work in progress.
3. Financial (Vehicle tracking to allow auto billing).
- Financial information accuracy and faster decision making capability.
  - Improve corporate governance and transparency.
  - Improve cash management.

- Reduce overall finance costs.
4. Sales and marketing (Advertising through websites and personal profiling).
    - Improve interaction with customers.
    - Improve customer services.
    - Improve on time delivery.
    - Improve order entry.
  5. Supplier.
    - Improve supplier performance.
    - Tying the supplier to the ERP system.
    - Increase the interaction between supplier and organisation.
  6. Customer.
    - Better customer satisfaction.
    - Improve the interaction between organisation with customers and suppliers in a long term plan.
    - Better customer responsiveness.
    - Improve customer flexibility.
    - Tying the customer to ERP system.

### **3.3.2 Limitations of ERP system**

- Lack of boundaries created by ERP system in a transport organisation can cause problems of who take the blame, lines of responsibility and employee motivation. Some individuals may abuse the information if they get information that was not intended for them.
- The installation of the ERP system is costly. ERP consultants are very expensive take approximately 60% of the budget.
- The success depends on the skills and experience of the workforce, including education and how to make the system work properly.
- Resistance in sharing internal information between departments can reduce the efficiency of the software.
- The systems can be difficult to use.



- Change of staff, companies can employ administrators who are not trained to manage the ERP system of the employing company, proposing changes in business practices that are not synchronized with the system.
- Having an ERP system has many advantages, but does not guarantee the total success of the company. Organizational culture, know how to involve staff and anticipate changes that will suffer the organization using this system of administration, are important elements for the completion of the implementation.
- The effectiveness of the ERP system may decrease if there is resistance to share information between business units or departments. Due to strong changes that implementation of the ERP system brings in the culture of work, there may be poorly trained or disinterested in making use of the same staff.
- The benefits of having an ERP system are not presented immediately with the implementation of the software, they will be evident long after the system is running.
- The culmination of the implementation depends on the ability and skill of the workforce, also involves education and training, to make the system is correctly applied.

## **2.4 Cloud Computing**

Cloud computing has recently emerged as one of the most promising and revolutionizing approaches of computing. Web 2.0 and Open Source are seen as the perfect background for cloud computing (Sharif, 2009). It is apparent that the undeniable success of Web 2.0 social networking applications have certainly facilitated the promotion of the idea of collaborative software and the acceptance of the notion that the internet can be a respected, secure transportation platform, even for critical business applications such as the Automatic Identification Systems (AIS) on which all or most of the organizational core functions depend upon. AIS provides the hub that holds together all modern ERP subsystems and its usefulness for any organization regardless of its size is unquestionable. According to Wu and Lao (2009) Web 2.0 may be used to reduce the cost, improve the quality and lower the risk of ERP implementations by providing, for example, a repository system that supports ERP application implementations. Whether transport sectors would be benefited from such applications depends upon certain conditions such as the organizational level of Information System (IS) knowledge and the extent and depth of the required AIS/ERP implementation.

**Figure 2.2: ERP on Cloud**



*Source: Taken from: “ERP on Cloud: The wind of change” by Krishnan.*

### **2.5 Security concerns for cloud based ERP implementation**

It is important for customers that are new to hosted services to carefully look into the security of the cloud based application being considered, expert says. With all that migrated data in someone else’s care, its protection depends upon the security levels of that vendor.

This maybe a minus for some users, as the customers may have little control over how their data is managed and protected. However, it may also be a plus as the vendor of the cloud systems may have more robust security measures and more resources to apply to security than a mid-level company. “In an on premises situation, one would have control over every details of security that can lead to loopholes being developed if the information technology team is not up to par and if they are not able to dedicate most of their time to data security” (Garrely, 2015). “With a cloud system, they are making the investments in developing top of the range IT teams that is dedicating all of their effort and time to keeping your data stored on their systems secure.

## 2.6 Infrastructure Considerations in ERP System Implementation

The root of ERP system can be traced back to MPR systems developed and implemented across the world in 1970s and 1980s (Wilson et al, 1994). Organisational expenditure on Enterprise Resource Planning (ERP) has also grown significantly during the 1990s and beyond. ERP systems have been adopted by the majority of large private sector firms and many public sector organisations in the industrialized world.

Several valued studies have been conducted on ERP systems implementation for the past decades. A case study presented by *Elragal and Al-Serafi (2011)* indicated association between Enterprise Resource Planning and industry achievements. Recognized of ERP systems adoption offers economic and operating benefits. Additional respected effort on ERP project implementation exist on, “The impact of ERP projects on Accounting Process”. The deliberation on the organisations who implement ERP systems and more attention was on boosting the flow of information, reducing cost, time taken to give response so that it can be kept at a minimal and relationship of suppliers and consumers. Organizations who implemented ERP systems gained many benefits as compared to the ones who ignore ERP systems as the researchers indicate. The researchers cited several benefits, however reduction in cost stood as the utmost vital of all.

A remarkable paper about ERP adoption existed in Indians’ Small to Medium Enterprises (SME) presented by *Kale, Banwait and Laroiya (2008)*. Done through interviews on ERP system dealers, subjects toward SME was acknowledged as well as highlighted. Matters discussed were: awareness, responsiveness, implementation method, how to management change, budget and restricted possessions. The researchers furthermore acknowledged elements which must reflected prior to system adoption which includes, planning on infrastructure, human capital forecasting, and suitable learning on ERP systems, organisational leadership support and suitable training. *Tsai et al. (2010)* presented a paper in relation to ERP systems and industrial trade procedures. They observed achievements of ERP systems and procedures issues through the means of questionnaires. Industry procedure and project relate to one another and its reliability must also deliberate on their significance. Consequently, it is specified that, “If organisations have no gap between system and business procedure, they can realize better ERP system performance”.

A study by *Somers, Nelson, & Ragowsky, (2000)* presents reactions to organisations who adopted ERP systems based on the idea of Critical Success Factors (CSFs) for instance, information technology adoption, information technology setbacks, support and involvement by leadership,

training of user, and change management. The reflection of these CSFs, companies will be able to successfully adopt ERP systems and increase business capabilities. They offered a reference model for implementation of existing theories. They studied the classical operation ideal as well as establish that it is good for lone devices and short-term dispersed operation aimed at important spheres.

*Baktashmotlagh, Bigdeli and Lovell, (2011)* has done another valuable work about combination of sensor and cloud systems. The researchers designed network sensor as well as ERP systems aimed at cloud systems integration. They described in what way resources can be reduced through sensors as well as reconfiguration of sensors through ERP methods data. They made use of dispersed resolution presentations and ERP systems towards producing data allied to transmission occurrence of sensors. For gain access to sensors information from ERP databank, they used caching and indexing approaches. Through their proposed design, it is possible to manage resources and protect energy by means of cloud method and ERP data.

*Yaseen (2009)* offered a descriptive case study on issues affecting ERP adoption. He deliberated on pharmaceutical businesses that implemented ERP systems. He scrutinized issues aimed at successful and unsuccessful adoption of ERP systems in terms of organizational performance and abilities and purposes of ERP systems. His discoveries revealed that abilities of the ERP systems were not exploited properly or never exploited by pharmaceutical businesses under deliberation. Results also indicated that functions existing in the systems were not appropriately used and only 10% of utilities were utilized. Another cause for ERP systems' failure is that ERP adaption is expensive and multifaceted. Other reasons that can also upset ERP systems either straight or incidentally are user approval, dependence societies, cultural attitude and board comportment.

*Isse (2010)* deliberated on implementation of Cloud Computing (CC) and integration for innovative business ideals. He observed existing business models such as SAP and their relation to Cloud Computing. He recognized two possible models for implementation of Cloud Computing in business models. In the first model, Cloud Computing works as a new extension without troubling seriatim business models and in another model, Cloud Computing works corresponding as incessant approach. With the benefits of Cloud Computing, business takes the benefits of technology to cut costs of expansion. With implementation of technologies and Cloud Computing, organizations make benefits even though menaces and glitches are still there. *Saleem*

(2011) deliberated the advantages and disadvantages of Cloud Computing implementation for organisations in term of budget and safety. He conducted case studies with Cloud Computing consumers and suppliers. He collected information through structured interviews and semi-structured interviews. Data analysis was finally carried out to come up with a decision. His concluding report indicated that budget and safety are key concerns for organisations.

The main capabilities needed for an ERP adaptation are team-building and communication skills so called “soft” skills. These capabilities are essential since integration of different departments or organisations can affect operations. The different departments have to practice the same terms for the identical inventory, to be cognizant of the activities prepared in one department have impact on the actions in another department. Another important skill is trust among personnel and associates, and alacrity to share data (*Stananou, 2009*). Information Technology (IT) development specialists have to learn more about the business procedures, and business procedure specialists have to learn more about the IT systems (*Baskerville et. al, 2009*).

Zimbabwe as a country have a number of companies that have implemented ERP systems for a more than fifteen years and these companies are functioning well. The list of these companies includes: Zimbabwe Revenue Authority (ZIMRA), British American Tobacco (BAT), Unilever South East Africa (SEA), Telone, Zimbabwe Electricity Supply Authority (ZESA), Grain Marketing Board (GMB), Hwange Colliery Company Limited (HCCL), Dairibord, Tetrad, Sakunda Energy, Zimbabwe Mineral Development Corporation (ZMDC), Nestle Zimbabwe, Savanna Tobacco and recently National Social Security Authority (NSSA) to mention but just a few.

Organisations situated in countries facing erratic power supply, like what is being experienced in Zimbabwe, may not be an appropriate location for implementing a cloud based ERP system, unless there is a better alternative. Moisture and dusty may also restrict the choice of appropriate technology because they shorten the lifespan of the hardware. Internet infrastructure considerations are problematic in less developed countries like most of the Southern African Development Countries (SADC).

One of the most important thing that an organisation should have when implementing an ERP system is ownership of the project. Because so many changes take place and its broad effect on almost every individual in the organisation, it is important to make sure that everyone is on board and will help make the ERP system is a success.

## **2.7 Role of leadership in ERP Systems Implementation**

Several writers have recognized the significance of resilient systems implementation leadership in the form of project champions, executive sponsors, project managers and steering committees (Beath 1991, Morris 1996). The terms of Chief Project Officer (CPO), project champion, project sponsor, project leader and project manager are commonly used in Enterprise Resource Planning (ERP) implementation projects and there is still misperception about their relationships. Usually, ERP systems are software packages comprised of many components, for example, human resources, sales, finance and production, providing cross-organization assimilation of transaction based data during entrenched business procedures. The project manager needs to basically warranty everything to go as per schedule.

During ERP adaptation process, project leader's role do not exist formally. They also mentioned that in some companies, the project sponsor cover as the project manager; in some circumstances, a leader arises from among the available leaders. It is important to explain perceptions about the role of leadership in pioneering change management in ERP implementation with an organisation.

### **2.7.1 Change management in ERP systems**

While reviewing texts concerning the introduction of change management in organisations, it be able to be seen that management of change refers to all actions related to communication between procedures and individuals. Proper movement of information is important throughout the project implementation and as such it is the utmost and the first significance aimed at every change in the organisational. People react to change positively when they have an understanding of its tenacity and significances (Williams and Williams, 2007). Enterprise Resource Planning adaptation consequently needs an enormous amendment to the structure of the organisational and disturbs the manner people used to do their duties and their interaction therefore it is important to have a policy, system as well as the techniques of system implementation (Al-Mashari and Zairi, 2003).

### **2.7.2 Impact of change**

Senge (1990), claimed "Failure to sustain change recurs again and again, despite substantial resources committed to the change effort, many of which are bankrolled by top management,

talented and committed people driving the change, and high stakes. Executives feeling urgency for change are right; however, organisations that fail to sustain significant change end up facing crises. By then, their options are greatly reduced and even after heroic effort they often decline”.

Senge (2010) gave accession in connection to Kotter (2005) method to management of change. Kotter’s (2005) stressed that, if leaders fail to generate a sense of urgency around the essential for change and trail through the stages, the change might flop. Schiavone (2012) perceived that change management often disregards the “people” feature of change and this shakes the capability to change.

Aloini et al (2007) and Schiavone (2012) recommended that underrating the determination intricate in management of change might cause in system catastrophe. Clash rising owing to the conflicting needs of participants in the project also needs to be addressed as and when it arises rather than in a collective way. It is hence dire that the similarity among ERP schemes and culture within an organisation is a necessity for effective ERP implementation as highlighted by (Gallagher and Gallagher, 2012).

Hong and Kim (2002) said that change can be painful, upsetting, frightening and at times categorical terrifying. Depending on persons, change in the place of work can also remain challenging, when job descriptions are changed, divisions are merged or different leaders are introduced. Agreeing with Pansiri (2005) version, change has anticipated emotional phases which look like the grieving procedure and refer to ordinary retorts to change. Editors perceived that organisations have to appreciate and very conscious of the phases, which are; “shock, defensive retreat, acknowledgement, acceptance and adaptation”, so as to be of assistance to employees as they adapt to change management. Further discussions are that, “It has to be recognized that people go through each phase at their own individual pace and it is significant for employees’ needs to be reinforced all the way through the change process to help them to adjust to change, by monitoring and realizing change over a helpful work atmosphere”. On the importance of communication, Kotter (2005) argued that communication is important to assist employees to move through phases so that they appreciate the benefits of the change to the organisation and mostly what’s in it for them as individuals. Change involves considerate forecasting as well as thoughtful application, as well as consultation with, and participation of, all individuals la-di-da by the changes. The leadership role is to demonstration to workforce motives of change and benefits linked to it.

Garvin and Roberto (2005) concentrated about significance of the changeover through which the companies need to traverse to advance to its preferred state. Change management has been the most required leadership skill as early as 1990's. Millis and Merken (2008), upheld that companies can positively achieve change by sustain employees' everyday duties. Workforces want to be maintained through change to assistance them acclimatize, monitoring and achieving change over a helpful work management atmosphere. Millis and Merken (2008) expressed that it is perilous for management of an organisation to give guarantee that employees need to be taken through stage by stage of change procedure. They also maintain, management's obligation to expedite and allow change and support employees to appreciate the motives, purposes and how to react positively according to worker's condition and competences.

## **2.8 Challenges in Implementing ERP**

Various scholars tried towards ascertain most important issue to effectively adapt to ERP system. Latest surveys agreed by numerous scholars, quoted in the effort of Al-Mashari et al (2006); Kumar et al (2002); Kim et al (2005); Nah et al (2004) and Zhang et al (2007), stated that up to seventy-five of change initiatives fail to produce pledged outcomes "the change efforts fail to produce what had been hoped for and yet always produce a stream of unintended and unhelpful consequences. These authors consider several factors, including organisational, user, and technical or cultural factors. They argued that the main challenge of implementations of ERP is to manage the elements of change in the organisation so that the intended, desired changes are implemented successfully and the unintended surprises that could lead to failures are avoided".

Currently no abridged model that can be adopted for the effective implementation of ERP systems in the transport sector in Zimbabwe. Mostly for the reason that comprises the issues involving employees of an organisation and its influence on the employees which vary with organisations. Umble and Umble (2003), itemized key issues which are liable for the disappointment of an ERP system as:

- Lack preparation or lack leadership;
- Modification of goals in the course of the project; and
- Lack of business leadership support.

Although they acknowledged need for change, employees have natural change resistance and recognition of most challenging change feature, that is, individual aspect is believed to be one of the success aspects.

Umbel and Umbel (2003), ascertain the presents of numerous aspects with impact to the



success of the ERP system, management of change has been recognized as being one of the acute success aspect, even though implementing a change management procedure appears to be a challenge for most business entities as it is frequently ignored.

Development plans, like ERP systems implementation comprise management of change therefore the receptiveness to in-house clients is essential for a company to elude the problems allied with change as indicated by (Al-Mashari and Zairi (2000), and Aladwani 2001). Lee and Lee (2004) said that, “the implementation of the ERP system usually leads to momentous changes in an organisation and anticipated benefits cannot be realised from their ERP system stashes unless these changes are managed effectually”. Hence it is dire to scrutinize the impact of change in a business setup and then study effect on the ERP system adaptation.

Millis and Merken (2008) clarified that, to moderate resistance, upcoming operators of system should be part of the team in the first stages of the ERP system implementation so as to generate sense of belonging and assurance to systems implementation. The involvement of upcoming users in the first stages of the project, has benefits because it describes the preliminary opinion for addressing ambiguity as well as uncertainty in organisations since there is potential need to follow new standards brought about by change. From the employee’s viewpoint, reaction to the change is perilous to mitigate problems linked with change (Al Mashari and Zairi, 2000; Aladwani, 2001). Therefore introduction of any change will need an approach on how to involve all employees and communicate to them the need to change as well as the benefits linked with it in order to efficiently achieve it. *Lee and Lee* (2004) stressed that several ERP system implementations have been considered as trivial disappointments. Many ERP systems end up failing to achieve the set goals that they were acquaint with. These disappointments are attributable to a range of causes; it is astonishing that nevertheless these aspects have been well-known and documented, organisations who are implementing ERP systems are still suffering similar problems.

Area of change management was also observed by several writers, such as, McAdam and Galloway (2007), Yusuf et al. (2004), Hong and Kim (2007), Al-Mashari (2003), Worley, Ramamurthy and Kirsch (2005), Huang et al, (2004), Aloini et al. (2007) and Shin (2008) all are in agreement that absence of good change management is one of the key causes of failure to ERP system adaptation. McAdam and Galloway (2007) perceived change management as one of the key causes of ERP systems adaptation failures. Lee and Lee (2004) said that, “it is vital to effectively manage ERP implementations as a program of wide-ranging organisational change proposals rather than as a software system control measure”. The writers maintained that this

method includes linking technology, task, people, organogram and business norms helps to achieve a clear implementation procedure. Thereby allowing identification, averting and alleviation of problems. Other areas are highlighted as part of the implementation, hence change resistance is reduced or in other circumstances eradicated.

Hong and Kim (2007) acknowledged that, resistance to change is a critical success factor to an ERP system successful implementation while McAdam and Galloway (2007) suggested cultural readiness for an ERP system implementation should be cautiously strategized. Aloini et al. (2007) advised that the underestimation of the work involved in change management may also have impact on system failure. Their results emphasized that several employees were not well trained on systems use and several are inexperienced in technologies and consequently a number of problems emanate. Wrong input of data, misuse of the systems, high training costs presented through the vendors, failing to incorporate ERP system to business procedures and need to employ support staff, all added to the problems of ERP implementation.

Although a rigorous preparation and learning remains measured as the critical success aspect by writers, Worley et al. (2005), indicated that, “the implementation of the ERP system after it is adopted does not only be determined by on training”. They disputed the needs to know how data and users adapt to each other, in terms of person’s duties in the organisation and of his skills and capability. The aim of the study was to demonstrate in what way ERP system is enhanced by acclimatizing business procedures to human aspects by clearly taking into account, roles, capabilities as well as skills of personnel.

Ebrahim and Irani (2005), in their research on the electronic-government (e-government) architecture adoption and barriers, consider a model derived from ERPs implementation to classify the main barriers to the introduction of new technology in Public Service Commissions (PSCs). They found the observations made for ERP implementation are adaptable to e-government as both philosophies automate business process and integrate IT infrastructures. The researchers identified four categories of barriers in their model which are, IT infrastructure, security and privacy, IT skills, and organizational. This last one is of primary interest to this applied project and is identified as a key adoption barrier in the public sector. The organizational barriers observed in PSCs by Ebrahim and Irani (2005) are:

- A weak communication and cooperation between departments that slow down the implementation and adoption process as department are reluctant to share data with other

functional units, as the perception is that it could weak their authority.

- A weak leadership from senior public official as a new technology can be perceived as a potential threat to the established power.
- An unclear vision and strategy toward the implementation of new technology.
- A resistance to change from the high-level management busy working on multiple other conflicting priority.
- A strong desire to keep established business process, encouraged by a bureaucratic structure.

### 2.8.1 Framework for ERP implementation

Figure 2.3: ERP implementation Framework

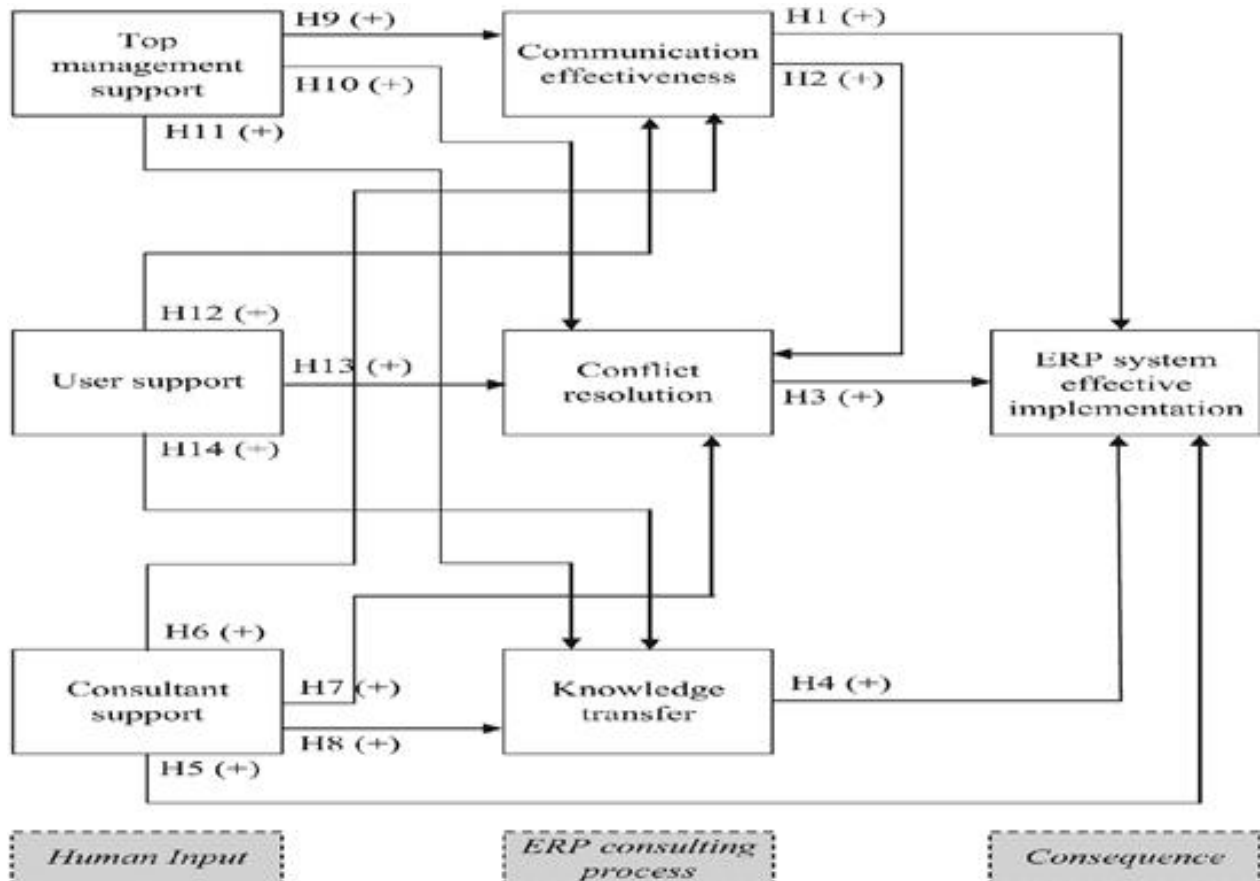

Source: Dimitrios, (2010).

Enterprise Resource Planning (ERP) system procurement and adaptation usually increase production and quality of work, as the ERP system come with standardization and generalization of complicated

operational procedures across the company (Dimitrios et al., 2010). Likewise, data is easily being transmitted, pooled and shared among users working in different business divisions (Amoako-Gyampah, 2007; Kemp and Low, 2008).

Causes of the common failures of ERP system effectiveness lies in a number of reasons, including poor change management strategies when rolling out implementation (Bradford and Florin, 2003; Hong & Kim, 2007; Marnewick and Labuschagne, 2006). Other causes include non-availability of a framework for ERP implementation, so the project managers will only do what they think is the best thereby fail to properly implement the ERP systems. More analytically, the proposed “ERP implementation Framework” highlight the steps that has to be followed when the transport company needs to successfully implement its cloud based ERP.

**Figure 2.4: Cloud Mobile ERP System Component**

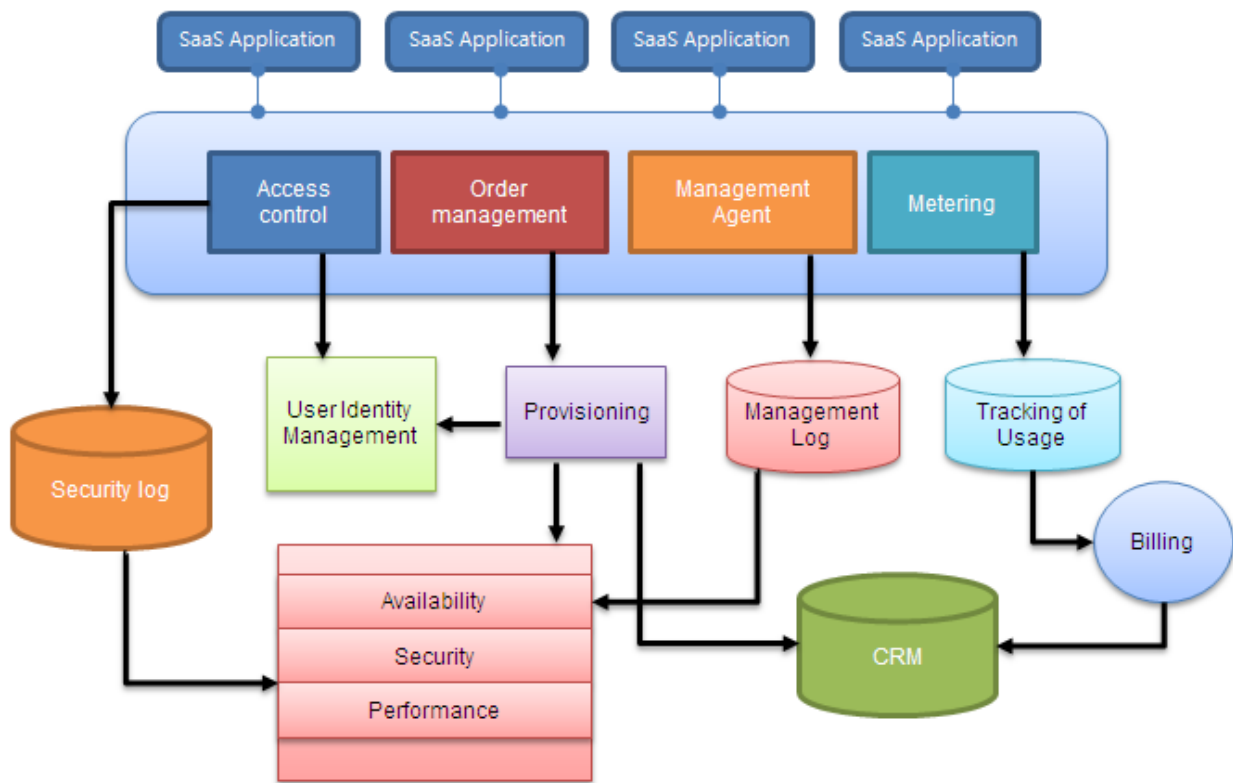

*Source: Gelogo (2014).*

This is whereby the data and software are hosted by an independent vendor on the cloud. The above framework is a general framework and is more suitable to manufacturing industry and not suitable for transport sector.

**Figure 2.5: Cloud ERP evaluation Framework**

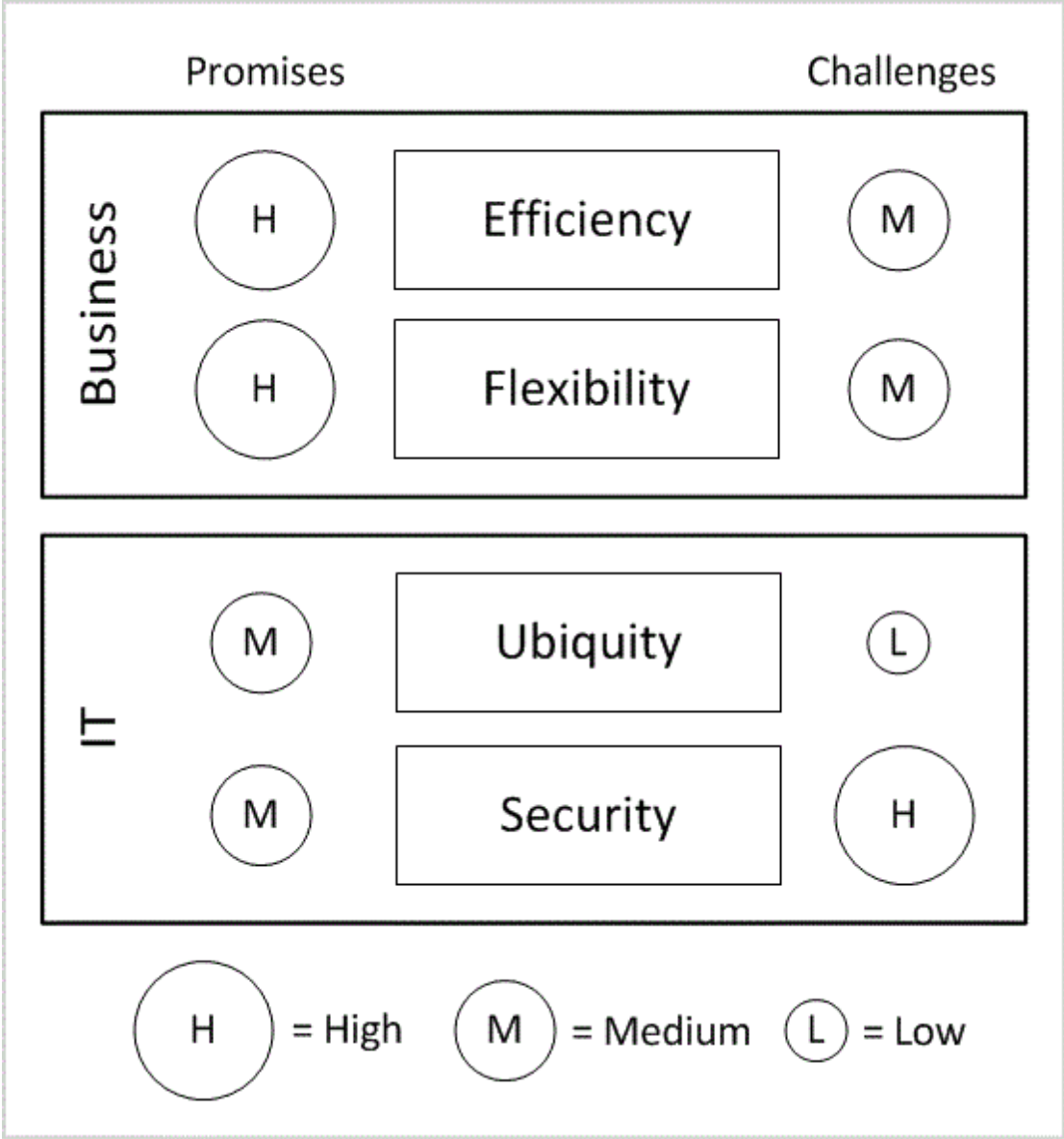

Source: Zhong (2014).

The above framework centers on business and Information Technology (IT). These two domains are adopted from the Strategic Alignment Model (Henderson and Venkatraman, 1993), which on the

interdependence between business strategy and information technology strategy. The framework fall short of the steps and who should be involved in the implementation of ERP system, so it cannot be used in transport industry but can be used to evaluate the after the implementation of the cloud based ERP system.

## **2.9 Conclusion**

Researcher has the view that, the framework for the cloud based ERP implementation have to be well designed, combined and focus on people, so that overtime it logical develops to a way that makes it adds value to the users, thus bringing users aboard, controlling and assist them to rich desired state. McCarthy and Eastman, (2010), also reasoned that, “Implementation framework for the technology is not just the first but the crucial step because it does not only generates value but influences realization of the system implementation to occur. For technology to create value, it requires people to realise its benefits”. Parastatals uniqueness reside in its bureaucratic silo culture and structure. While defined frameworks are similar and consistent across the literature, the content of the frameworks must be adapted to the parastatal’s context. Several ERP implementation frameworks exist and are well documented. There is a lack of framework for the ERP implementation in the transport business sector specific literature. Therefore, there is a gap in the literature as private companies first adopted ERPs and parastatals are only now looking into this type of IT technology. The next chapter gives details of the objectives and appropriate methodologies to attain the objectives.

## **CHAPTER 3: RESEARCH METHODOLOGY**

### **3.1 Introduction**

The main objective of this study was to develop the framework for the implementation of operational cloud based Enterprise Resource Planning (ERP) for transport industry in Zimbabwe. It involved a comprehensive study of the available frameworks and facts about the ERP systems being used by the respondents; exploration of the security dimensions. The secondary objective is the identification of opportunities for cloud based ERP to improve business functional performance and find out the security requirements for the cloud based ERP system implementation in the transport business sector in Zimbabwe. This was done through questionnaires and interviews.

The chapter give details of the objective and an appropriate methodologies to attain those objectives. Polit and Hunger (2004) refer to methodology as the ways used in obtaining, organizing and analyzing data used in a research project. Methodology can be described as to be concerned with the design, setting, sample, methodological limitations and be data collection and analysis techniques in a particular study (Burns and Grove, 2003). Usually the methodology selected will be influenced by the nature of research questions that need to be answered in the research.

The study also evaluated the influence of risk issues and ERP system infrastructure requirements for the successful implementation of cloud based ERP in the transport industry in Zimbabwe. Followed by model justification through one case studies involving review investigation of the system being used at CMED (Pvt) Ltd. The research methodology has to be strong in order to reduce errors in the collection of data as well as data analysis. Due to this, several approaches that is questionnaire, structured interview, unstructured interview and case study were chosen for data collection. Defining of the research method, participants, data collection method, and data analysis process for the research study.

### **3.2 Research Methodology**

Research approach is a confidence about the way in which information on an occurrence have to be collected, evaluated and be used. When tasked to do a research of this type, there is need to consider dissimilar study examples and problems of ontology and epistemology. As limitations define insights, views, norms and the type of truth and reality (information of that truth), they can impact the manner in which the research is commenced, from proposal up to the ends, and it is vital to realize and debate these issues so as to congruent the approaches to the nature and purposes of the specific review are implemented, and to make sure that researcher partialities are understood, uncovered, and minimalized. Research approach can likewise be qualitative or quantitative or both.

Research is “a blueprint for conducting a study with maximum control over factors that may interfere with the validity of the findings” (Burns and Grove, 2003). Polit et al, (2001) describe a research design as the researcher’s overall for answering the research question or testing the research hypothesis. The research method is non-experimental, qualitative, exploratory-descriptive and contextual.

The study was carried out by means of a qualitative method research method. The qualitative technique made use of strategies that gather open-ended, initial information by means of approaches like descriptions and case studies.

### **3.3 Qualitative Research**

Qualitative research was described by Creswell (2008) as “a way of exploring and understanding the meaning individuals or groups ascribe to a human or social problem”. This research model was used to get concepts on the ERP systems that CMED (Pvt) Ltd implemented. The qualitative research assist in getting an insight in the reasons blocks transport industry from effectively implement cloud based ERP systems. It also assisted to discover dominant tendencies in the Transport Industry in Zimbabwe.

Given the aim of this research, deductive approach shall be considered as data gathered and analyzes from all proposed origin and shall be used to formulate necessary recommendations to CMED (Pvt) Ltd. “A deductive approach is concerned with developing a hypothesis based on



existing theory to test the designing a research strategy to test the hypothesis” (Wilson, 2010). Deductive approach can be derived from the propositions of the theory. In other words, deductive approach is concerned with deducting conclusions from premises or propositions. “Deductive begins with an expected pattern that is tested against observations, whereas inductive begins with observation and seeks to find a pattern within them” (Babbie, 2010).

It has been stated that “deductive means from the particular to the general. If a causal relationship or link seems to be implied by a particular theory or case example, it might be true in many cases. A deductive design might test to see if this relationship or link did obtain the results on a more general circumstances” (Gulati, 2009).

### **3.4 Case Study**

A case study was defined by Saunders (2009) and Robson (2002) as “a strategy for doing research which involves an empirical investigation of a particular contemporary phenomenon within its real life context using multiple sources of evidence”. “A case is a bounded entity such as an organisation which acts as a unit of analysis”. “The purpose of using many case study method is to be able to relate findings from one case with findings from another and decide whether they are the same and be able to generalize from the results” Saunders (2009). Information be present on ten CMED (Pvt) Ltd branches through approaches such as thorough interviews and questionnaires observation and questionnaires. It is essential in that, a case study technique can be used to assess and analyze diverse occurrences. Another benefit as a result of using case study to gather information is its capability to use information from dissimilar bases to make it stress free to analyze. Yin (2004) eluded that, “Designing a good case study includes case definition, justification of the choice of case study type, and adopting theoretical perspectives”. Data on different systems being used, security requirements and prospects were collected using this technique.

### **3.5 Research Strategy**

Research strategy is one specific course of action being followed in a specific instance. A course on methodology would include different ways of dealing with different research problems. Research strategy would be a unique choice of research method adopted to one specific problem. In this research a case study approach is used as the research strategy.

The following are the steps that were followed in carrying out the research:

1. Established Goals

What was to be learnt in the research was listed for example; the ERP system employed by CMED (Pvt) Ltd.

2. Sample determination

The target groups were identified in this step. There are two main components in determining whom to interview. The first is what kind of people to interview which is the target population and the next thing to decide is how many people should be interviewed. The sample size was determined by factors such as time and budget.

### **3.6 Strategy for Sampling**

Sampling is a method used to select participants to take part in the study. Mcleod (2014) defines a sample as a group of people who take part in the investigation. To response to the research questions, a purposive selection strategy is used to choice the number of participants to be involved in the research study and sites where research is supposed to take place.

#### **3.6.1 Purposive strategy for sampling**

*Oliver*, (2006) defines purposive sampling as a form of non-probability sampling in which decisions concerning the participants to be included in the sample are taken by the researcher, based on various reasons which may include specialist knowledge of the research issue, or capacity and willingness to participate in the research. *Tongco*, (2007) also referred to purposive sampling as judgmental or subjective sampling purposive sampling relies on the researcher when selecting units of analysis, for example participants. Target population is the group that we are interested in studying.

#### **3.6.2 Targeted populace**

Targeted populace denotes the amount of participants deliberated to take part in the study. The emphasis of the study is all personnel of CMED (Pvt) Ltd who use and support ERP technologies. CMED (Pvt) Ltd is the biggest transport company in Zimbabwe and is wholly owned by the Zimbabwean government and decision making with regards to cloud based ERP system implementations was locally made.

### **3.7.3 Sample Scope**

Sample scope was reached at centered on time, budget and access. There is limitation in terms of interval and financial plan for the research to be completed. The model for CMED in which the research was conducted will include 4 personnel in Information Technology systems support as well as computer hardware support, 8 customer care officers who deal with clients through ERP systems. The group as well involved top managers accountable for strategy. 4 participants each from other sections be part of total sampling size and 3 participants comes from the buying office. CMED was selected to be the case study since it has the largest transport company by number of vehicles and business units translate to a large number of personnel.

### **3.7 Methods of Collecting Data**

The business dictionary defines data collection as “The collection of data from surveys, or from independent or networked locations via data capture, data entry, or data logging”.

#### **3.7.1 Primary Data**

The primary data was collected using archival records. Marshall and Rossman, (2011) define records archive as “records gathered from the organization and they add to other qualitative methods”. Historical archives kept in computerized records were there to analyze to come up with the conclusion about acceptance and procedure and when joined with additional research techniques may define problems met in transport industry.

#### **3.7.2 Secondary**

Interviews were used to collect secondary data as done through face to face investigations. Srivastava and Rogo (2011) says “Data can be collected by using unstructured and semi-structured interviews (qualitative research) or by using structured interviews”. Interviews were conducted in board rooms at different CMED (Pvt) Ltd provinces scattered all over Zimbabwe, through face to face as well as telephone interviews using open ended questions and the participants’ responds by giving opinions all from CMED (Pvt) Ltd. It was essential as it helps in getting the moods of the participants through non-verbal ways. The participants provide their discernments on what they consider to be done in circumstances where they sensed there were problems in which ERP systems are being conducted. Structured questions alongside survey was used so as to collect more data to supplement the questionnaires that were given out.

The student directed the in-depth interviews personally. Arrangements for appointments with the target population was made for individual discussions (interviews) nevertheless it was a challenge to establish an interview as participants are always busy with their daily work.

### **3.7.3 Questionnaires**

Marshall (2006) says questionnaires “entail several questions that have structured response categories; some open-ended questions may also be included. The questions are examined (sometimes quite vigorously) for bias, sequence, clarity, and face-validity”. Mostly they tried using a sizable number of participants so as to decide the effectiveness as well as reliability. The response ratio is 75%. Heads of departments were given the questionnaire for distribution to their subordinates.

### **3.7.4 How the questionnaires were distributed**

Emails were used to distribute the survey questionnaires and some are given to depart head who in turn to their subordinates for completion. Explanation was given by the researcher about how the questions were to be answered. The department heads offered to get the completed questionnaires from their subordinates and the ones on email were replied through email. High return rate was archived through the hard copy questionnaires since it was easy to make follow ups and all the respondents were in a close proximity at the same workplace with the researcher. Emailed questionnaires gives some problems to the researcher in getting them back because participants are always busy so there was a low return rate.

## **3.8 Findings’ Reliability and Validity**

They are of paramount significant in the study since it quantify exactly how worthy the results are to the research.

### **3.8.1 Findings’ Reliability**

Yin (2004) said, “Reliability objective is that if another investigator follows the same procedures as used by an earlier investigator he/she will arrive at the same findings and conclusions by minimizing errors and biases in the study”. Good record keeping for all the processes was done to allow repeatability of the research. Information from diverse study methods was compared to determine the reliability of the research. The supervisors provide expert advices to the student in terms of checks and balances during the research.

### **3.8.2 Validity**

Credibility of the research should be achieved so as to be believed. Internal and external are the two types of validity. Yin (2004) said, “There are so many threats to internal validity and one of them is when a researcher fail to correctly conclude that event X led to event Y not eloquent that it was some third factor Z that triggered the outcome. Internal validity also deals with issues of inference”. Yin (2004) said, “In Case studies an inference is made every time an event cannot be directly observed and an investigator will then infer based on interviews or documentary evidence. External validity deals with the problem of knowing whether a study’s findings are generalizable beyond the immediate study. Survey research relies on statistical generalization whereas case study research relies on analytical generalization”. Nine provinces are used to come up with the study findings and the findings can be generalized to any other transport department in Zimbabwe.

### **3.9 Analysis of the Data**

Kawulich (2004) said, “Data analysis is involves the process of reducing a large sample of gathered data in order to understand that data”. Also described as a method to evaluate and appreciate information, so as to respond to research questions.

#### **3.9.1 Narration**

Narration is how data is transformed in meaningful information. This type of data analysis is mostly used alongside qualitative data collection method.

#### **3.9.2 Coding**

This method comprise establishing and combining information so that relations can be known and an analysis be done. Information can be systematic and rearranged in order of significance and sort criteria. Problems are arranged or organized as technical and human problems to make it easier to analyze.

#### **3.9.3 Data Interpretation**

The student can effortlessly describe the connotation from the description (narration) and coding so as to assist the student to get an understanding of the whole process. The information can be compared against set standard or against the respondent’s understanding and a reasonable sequence of suggestion put together. Suggestions can built on elucidations of results. Information

collected by way of detailed dialogues (interviews) should remain understood to get its significance.

#### **3.9.4 Data Confirmation**

Confirmation assistances to distinguish personal thoughts and interpretation from research data. An assessment of procedures have been done as well as triangulation were made. Response to respondents were done as a way of giving confirmation of the research procedure.

#### **3.9.5 Data Presentation**

Data presentation remains best important step after confirmation. Information has to be presented in a way that the heirs will simply appreciate and this would lead to additional investigation. The essential information would have to be highlighted as well as recommendation from associates will be welcome. Numerous computer tools will be used to present information will be important at this level.

### **3.10 Ethical Consideration**

Davis and Resnik (2011) defines ethics as “what is morally and legally right in conducting research”. Drew (2007) also says “ethics is very important in the conduct of research and the manner in which research is always under scrutiny”. There is need to make sure succeeding issues are perceived while doing the research.

#### **3.10.1 Obtain Consent**

Participants will not be forced by the researcher to participate in the research but consent will be sort before they can participate. The process is very essential for the research to be successful. This research will not threaten the security of the participants in any way whatsoever.

#### **3.10.2 Privacy and Confidentiality**

It is the duty of the researcher to guarantee the confidentiality of the data that was provided by the participants during the research time and to make sure that the data is only used for the purpose if that particular research only. The respondents will remain protected during as well as after the research study.

#### **3.10.3 Deception**

No participant will be will be forced to do anything without his/her consent since everything will be properly explained to in detail so that the participants will participate knowingly.

### **3.11 Conclusion**

Chapter 3 dealt with the methodology that provide guidance to the research. This methodologies assist in coming up with the framework that can be adopted in the transport business sector. The research made use of a qualitative method and information was gathered using questionnaires which were written in English and printed copies where distributed to the participants. The following section presents results of the research study and make appropriate endorsements.

## **CHAPTER 4: DATA PRESENTATION, ANALYSIS AND DISCUSSION**

### **4.1 Introduction**

The purpose of the research is to develop a framework for the implementation of cloud based ERP system in the transport business sector in Zimbabwe. This chapter aims to present and analyze the information collected through data collection phase and deliberate on the data. These results give solutions to the research questions expressed in the outline of the research. Information from interviews, questionnaires and case study is presented in this chapter in a layout that is easy to analyse. The data is being analysed using statistical analysis in order to give conclusions on the implementation of cloud based ERP in the transport business sector in Zimbabwe.

A qualitative study engaging a multi-site case study methodology was accompanied with data collected from observations, interviews and document collection (Yin, 2009; Merriam, 2009). Findings presented helped to respond to the succeeding research question:

- How to come up with the framework for the implementation of cloud based ERP system in the transport business sector in Zimbabwe?

### **4.2 Background of Survey Participants**

This includes the participants' age, qualification, employment status and gender.



#### 4.2.1 Participants' Gender

**Table 4.1 Participants' Gender**

Gender	Questionnaires		Interviews	
	Male	Female	Male	Female
Head Office	9	5	5	2
Midlands	3	2	2	1
Masvingo	4	1	2	1
Mash East	2	3	1	1
Mash West	4	2	1	2
Mash Central	5	1	2	1
Manicaland	6	0	2	1
Mat North	3	1	2	1
Mat South	5	4	2	1
<b>Total</b>	<b>41</b>	<b>19</b>	<b>19</b>	<b>11</b>
<b>%ge</b>	<b>68%</b>	<b>32%</b>	<b>63%</b>	<b>37%</b>

**Figure 4.1: Participants Gender.**

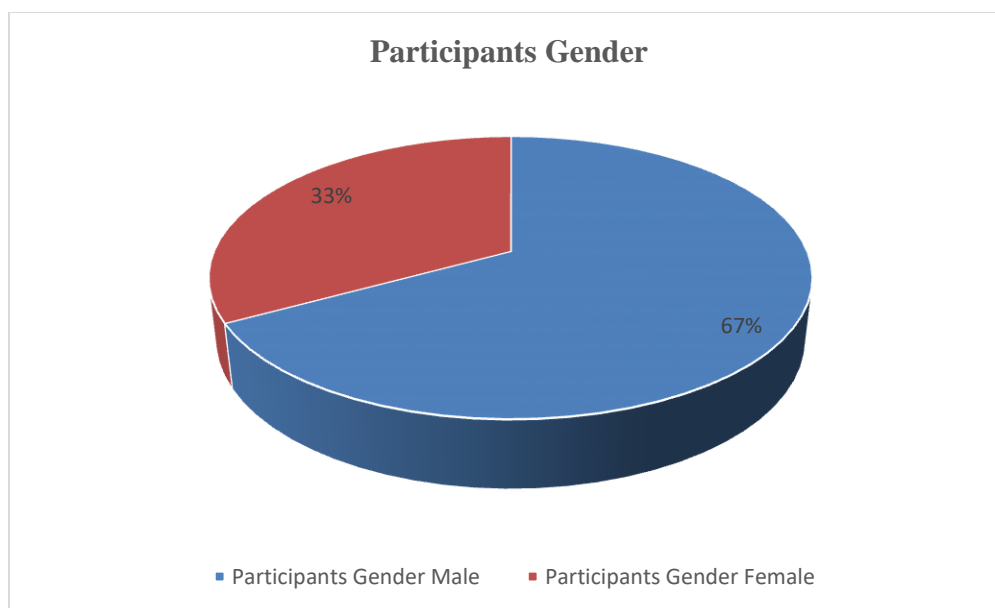

The results demonstrates that 68% of the questionnaire were distributed to male participants and 32% were distributed to female. All the participants were drawn from CMED (Pvt) Ltd, with the majority being drawn from its head office in Harare in which giving out of questionnaires was easy. The highest number of questionnaires were reverted. Of all the participants who took part in interviews 63% were male and 37% were female.

#### 4.2.2 Participants' Age

**Table 4.2: Participants' Age**

Age	< 25	25-to-35	> 35
Head Office	3	14	5
Midlands	1	3	4
Masvingo	1	4	3
Mash East	1	2	4
Mash West	2	4	3
Mash Central	2	1	6
Manicaland	0	4	5
Mat North	1	1	4
Mat South	2	4	6
<b>Total</b>	13	37	40
<b>%ge</b>	14%	41%	45%

**Figure 4.2: Participants Age.**

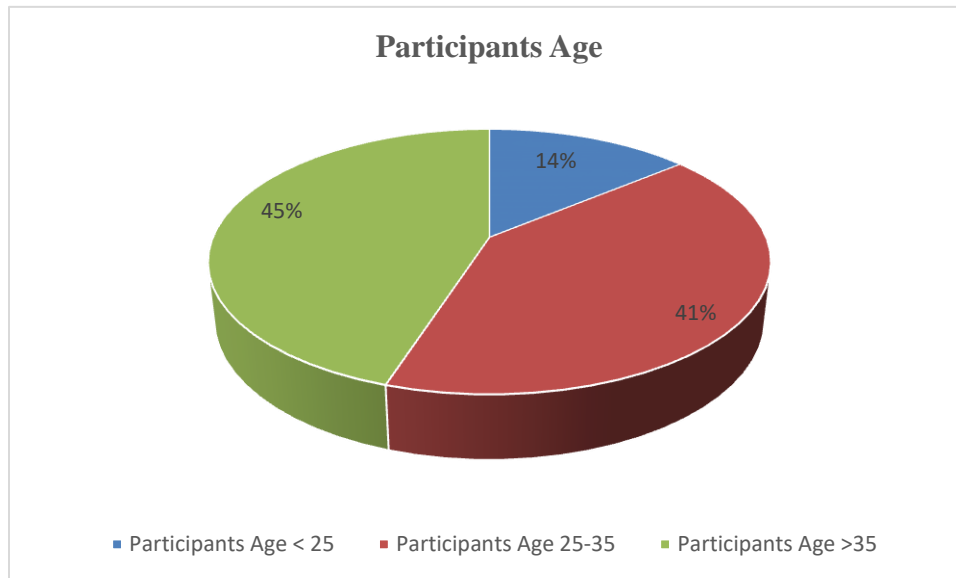

It can be seen from the results that the majority of the participants were above 35 years and they constitute 45%. Few participants were below 25 years of age which constitute 14% and 41% comes from the age between 25 and 35 years.

#### **4.2.3 Employment Type**

**Table 4.3: Employment Type.**

<b>Employment Type</b>	<b>Number of Respondents</b>	<b>%ge</b>
Permanent	50	83%
Contract	0	0
Part-Time	0	0
Apprentice	6	10%
Student	4	3%
Total	60	100%

**Figure 4.3: Employment type**

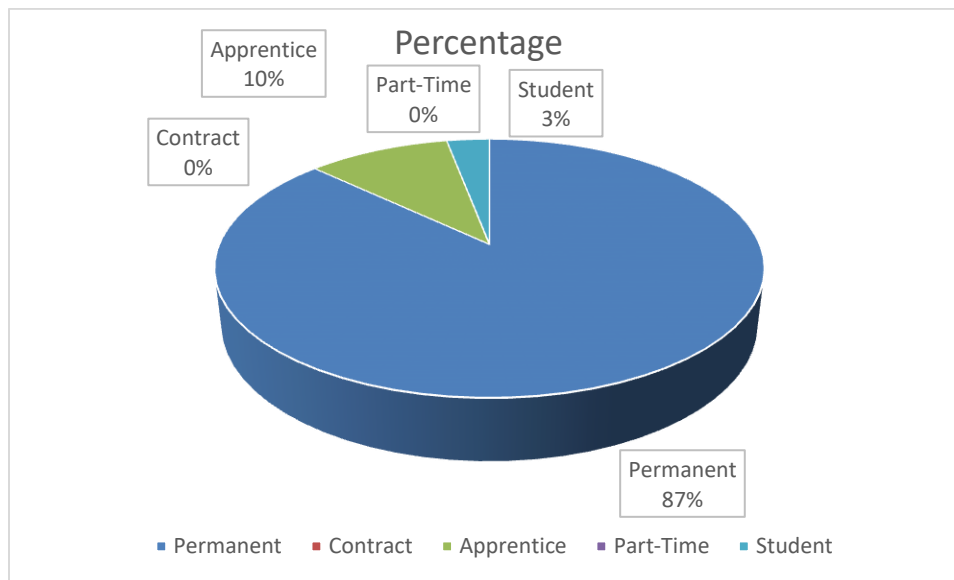

Most of the responses came from individuals who are permanently employed at CMED (Pvt) Ltd, who contributed 83% of the response. 10% comes from Apprentice who are on 4 years training for different technical skills. And 3% are students from various universities and colleges around the country of Zimbabwe.

### **4.3 Findings from Questionnaires and Interviews**

The purpose of this study was to develop the framework for the implementation of cloud based ERP system in the transport business sector in Zimbabwe. The first three chapters of this research give introduction to the issues surrounding the need to have the framework that can be adopted by all transport companies as well as the methodology design that can be used for this research. This section will present the findings that come from the information collected and analyzed using conceptual framework that was constructed for the purpose of this study.

#### **4.3.1 Enterprise Resource Planning Issues**

This section will look on the issue to do with ERP system and how it is being used and respondents' understanding of ERP systems.

#### 4.3.1.1 Participants' Experience with the ERP systems.

This section shows time period of experience of the participants.

**Table 4.4: Period of ERP system use by participants**

Period	No. of Participants	%ge
3-6 months	2	3%
7-11 months	0	0
1-3 years	15	25%
More than 3 years	43	72% <sup>S</sup>
<b>Total</b>	<b>60</b>	<b>100%</b>

**Figure 4.4: Participants' Experience with ERP Systems**

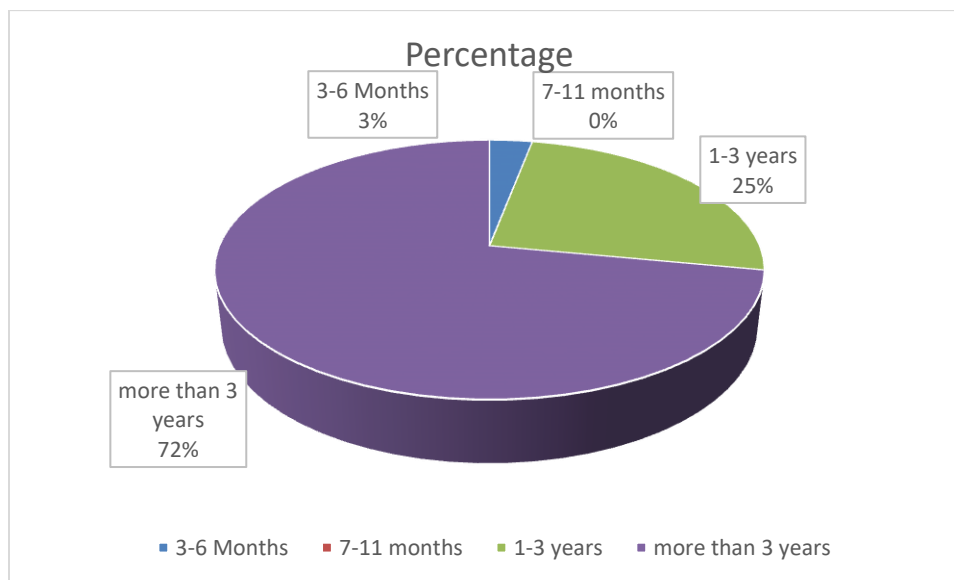

A large percentage (72%) of users have more than 3 years' experience of using the ERP systems that means they now know all the operations of the modules implemented and they can provide very helpful data.

#### **4.3.1.2 ERP system modules**

This section will look at the ERP system modules that are being used by the participants.

All the participants agree on the ERP systems modules that are being used as finance management and inventory management. There is an agreement on the need to increase the number of modules by adding more modules like personnel management, corporate governance, fleet management, sales marketing management, E-Ticketing/E-booking, workshop management and billing and telematics.

#### **4.3.1.3 What do you understand by the term ERP system?**

From the interviews and questionnaire carried out most participants have an idea about ERP system? Many participants says ERP system is a combined system that permits accounts, marketing relations and production transactions. Most highlighted ERP system as an instrument aided in enlightening the performance of the business. Many participants highlighted that ERP system helps in unifying, arranging and systematizing the business procedures. Participants demonstrated a respectable appreciative of ERP system.

#### **4.3.1.4 What is your view on cloud based ERP system as an alternative to On-Premises ERP system?**

From the interviews and questionnaires carried out the participants thinks it is a good idea to replace On-Premises ERP system with the one which is cloud based but their main concern was of the speed of internet in Zimbabwe as well as the cost of bandwidth here in Zimbabwe. Most of them highlighted that it is very expensive to run a cloud based system basing on the prices of the bandwidth in Zimbabwe currently. The other issue raised was of cost of the hardware that is required to have access to the cloud. This idea was down played by others with in-depth knowledge who said it is cheaper to run a cloud based system as compared to On-Premises since there is no cost of expensive servers and no work for security issue since the cloud service provider will have to employ qualified security personnel to guard your data.

#### **4.3.1.5 What impact do you think cloud based ERP system will have on the convenience in providing services to the customers?**

Reports can be generated anytime and from anywhere, no need to wait for the end of the month for system synchronization to take place so that the reports will be generated. The system will be

online and reports can be accessed whenever the need arise. Cloud based ERP also promotes transparent and accuracy of data in the organisation.

#### **4.3.1.6 How else do you think On-Premises system could be improved?**

The only option is to go the cloud way if the organisation needs to remain competitive since it is the global trend these days. All other companies are going the cloud way and customers as well as suppliers want to associate with companies that are moving with time.

#### **4.3.1.7 What is your take on the use of ERP system in CMED (Pvt) Ltd currently and what are the benefits?**

Participants were pleased to make use of the ERP system. Most respondents highlighted that they got many of the benefits of ERP systems. Most participants highlighted that it was easy to integrate dissimilar processes and roles in the organisation through ERP system. Information access was made easier. A number of participants appreciated the speeding of transactions through the use of ERP system and responses to queries, and they revealed that ever since the introduction of ERP system, client services had been enhanced immensely.

#### **4.3.1.8 Can you highlight what you think were the reasons for ERP system introduction?**

The participants highlighted a number of reasons for ERP system introduction as listed below:

- Technological changes as recommended by the suppliers and customers.
- The coming in of latest information systems require companies to change drastically in this age of advances systems.
- Company's strategical plan had forced it to acquaint with ERP systems to develop and improve processes to handle upcoming requirements.

#### **4.3.1.9 Why do you think the implementation of ERP system was a right decision or it is a regret?**

Most of the participants concur that there are no regrets for the implementation of ERP system. Below are some of the reasons:

- Implementation time was short. The implementation only a few months.
- Business interruptions was at a lower scale.

- The impact of the ERP system was immediately realised since it enhance and speed the response time to queries and enquiries.
- Performance and work procedures were refocused and to a great extend improved.

**4.3.1.10 How do you think ERP system has progressed and can you highlight the factors that leads to its success?**

Greater visibility had made it easy for the executives to appreciate business procedures. To management furthermore now appreciate their part in ERP system adoption and extra associated corporate processes in a way which enriched entire business procedures and methods. Additionally, ERP system enhance administration of the corporate.

**4.3.1.11 Can you list the problems and challenges met during ERP system implementation and their effects to the company?**

Many encounters were acknowledged by participants. Below are the encounters highlighted by the participants?

Adaptableness: Most participants highlighted the failure by some staff adjust to ERP system. In the beginning majority of the staff were terrified by the introduction of the new system since they did not know what was happening to the data they captured into the system. Employees view the new system as a replacer to the employees. Eventually the fear drastically vanish as employees became used to working with the ERP system and start to enjoy it.

Many workers remained ignorant of the necessary adjustments. At the beginning workers were unprepared for the adjustments. It is easy for young generation to adapt to new system than the older generation. The conflict affects the implementation of the ERP system in the company.

Inadequate time was allotted for the adoption of ERP system resulting in many challenges.

**4.3.1.12 What measures should be taken to address the challenges? In addressing these challenges who should take a leading role?**

Most of the participants highlighted that all parties should be involved (employees and management) to adopt to the change that is taking place in the organisation. Moreover, participants should attend workshops on management of change so that they get to know what is expected from them. “If employees and top management had attended change management



workshops, it could have assisted the company to have a better understanding of ERP implementation”.

### 4.3.2 Training of Employees

This section will look into the training requirements of with ERP systems and get data from the participants on the experience with the system.

#### 4.3.2.1 What type(s) of training did you receive?

**Table 4.5: Types of Training**

Type of Training	Number of Participants	Percentage
Project term training	5	8
End user training	51	85
Traditional training	0	0
Web-based training	0	0
Did not receive training	4	7
Total	60	100

**Figure 4.5: Types of Training**

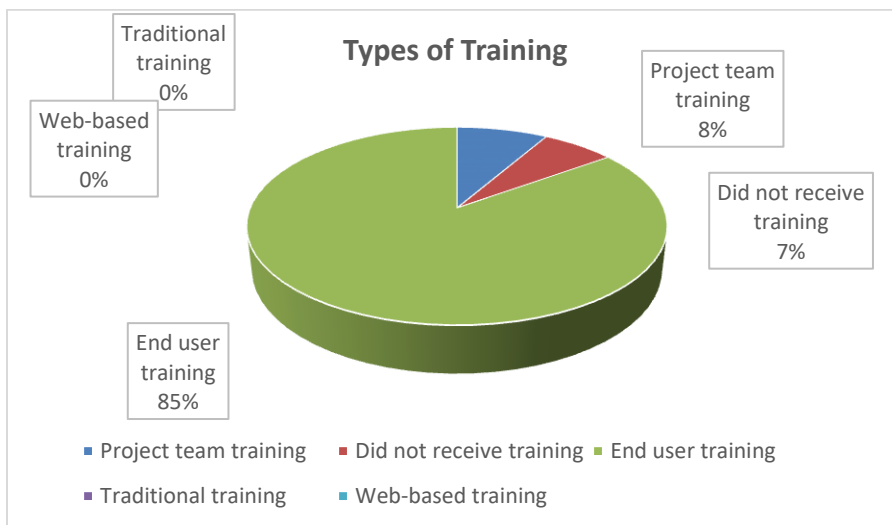

Many participants 85% received end-user training, 8% received project team, and 7% of the participants did not receive formal training that means they learn as they work. There results show that end user training is the one used to equip users with only skills to help them do their

day to day duties. Project team training is done mostly to the Information Technology staff and heads of departments to enable them to provide mostly support to the end users in time of need.

**4.3.2.2 If you receive training, how long does it take you to master the ERP system?**

**Table 4.6: Training Period**

Training Period	Number of Participants	Percentage
Master in a week	13	22
Master in a month	41	68
Master in three months	5	8
Master in six months	1	2
Still receiving training	0	0
Did not master	0	0
Total	60	100

**Figure 4.6: Training Period**

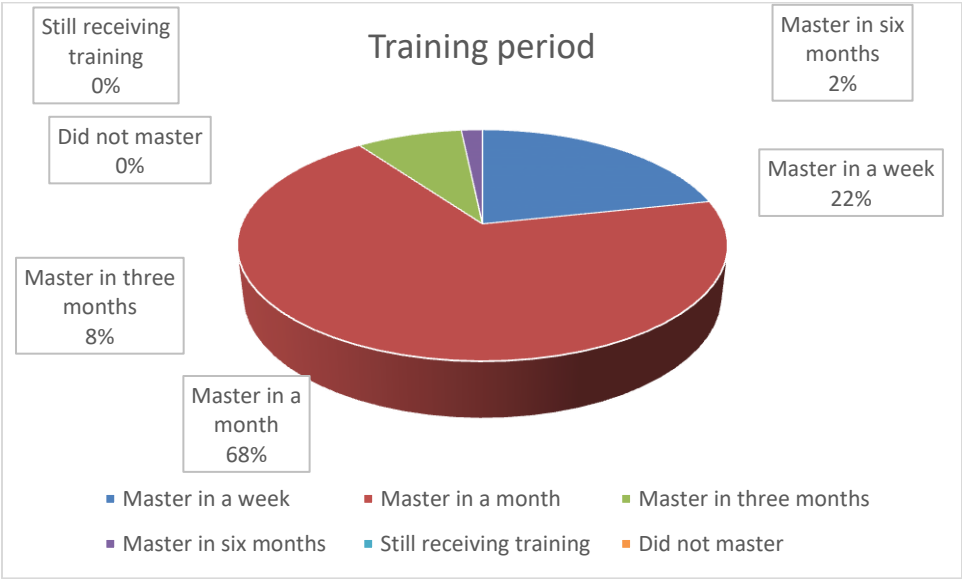

The results shows that a large number of participants 68% managed to master the concepts of training in a month. 22% managed to master in seven days of which most of those who says they managed to master in a week are from the Information Technology department who find it easy

to understand since they have programming background. There are some slow learners 2% of the participants like the old age people who need about six months to master the concepts.

### **4.3.3 Security issues associated with ERP implementation**

This section will look into the security issues associated with ERP systems and get data from the participants on the experience with the system.

#### **4.3.3.1 What type of security problems do you experience with the ERP system?**

The results from both the interviews and questionnaire shows that, on-premises ERP system has many problems since all the participants tick all the five problems suggested: unauthorized access, denial of service (DoS), system viruses, breach of security policies and ERP system abuse by users. Unauthorized access is whereby the user access the ERP system without permission.

#### **4.3.3.2 How often do you change your password?**

The majority of the respondents indicated that it is a company policy to change the passwords every thirty (30) days, although some tend to be ignorant of the issue but the system will not allow the user to continue using the same password after thirty days.

#### **4.3.3.3 What are the required combinations for the password?**

The respondents indicated that the password has to have at least one capital letter, at least be eight characters in length, at least one special character, at least one small letter and at least have a number. This question does not cause any problem since they said it's a company policy to include all the listed requirements for the password.

### **4.4 Discussion of Questionnaires and Interview Results**

This section do an in-depth look at the results of the research by analyzing the responses of the 30 question in the questionnaire (refer to appendix C). The response rate and usability for each question was exceptionally good with an average of 95.8%. The presented data highlighted that there are opportunities and challenges in the implementation of ERP system in the transport business sector. The challenges should be done away with as quickly as possible since we live in the world of competition where technology is moving at a fast rate, the competitor will take them as loopholes. There is need to adopt the opportunities since they act as competitive advantages.

#### **4.4.1 Research Participants**

Majority of the respondents were male as compared to female, showing that there are still few women who support ERP systems. There is need for the girl child to be educated and receive the necessary support as that which is given to her male counterpart. Most of the respondents were of the younger generation below the age of 40 years. As previously mentioned the title of this research is “A framework for the implementation of cloud based ERP in the transport business sector in Zimbabwe”. Coming up with the ERP system framework is the output of this research.

#### **4.4.2 Opportunities**

Most participants have confirmed that the introduction of the ERP system was a blessing to them since their duties were lightened and made easy, but their worry was that they can only access the system on premises. So there is need to transfer the ERP system to the cloud so the employees can access the system from anywhere and at any time. When the ERP system is transferred to the cloud it will be easier to communicate with both suppliers and customers. Majority of the services will be automated the likes of ordering of supplies and payments of goods, income tax, vehicle tracking will be done from anywhere and at any time with automatic generation of reports on demand and ledger accounts will be automatically synchronized.

#### **4.4.3 Challenges**

Majority of the respondents suggested that they were challenges in ERP system implementation in the transport business sector in Zimbabwe. Most of the participants highlighted that all parties should be involved (employees and management) to adopt to the change that is taking place in the organisation. Moreover, participants should attend workshops on management of change so that they get to know what is expected from them. If employees and top management had attended change management workshops, it could have assisted the company to have a better understanding of ERP implementation. From the information presented majority of respondents agreed that there are a lot of challenges during ERP system implementation as a result of poor communication between management and the rest of staff. These challenges need to be addressed and adequate time should be allocated to each and every phase of the implementation framework if the organisation need to successfully implement cloud based ERP system in transport industry.

## **4.5 Conclusion**

Data was collected using interviews, questionnaires and survey. The data was then presented and analysed in this chapter using tables and pie charts. The next chapter will be looking at conclusion and recommendations.

## **CHAPTER 5: CONCLUSION, RECOMMENDATIONS AND FUTURE WORK**

### **5.1 Introduction**

The aim of this study was to develop a framework to be used for the implementation of cloud based ERP system in the transport business sector in Zimbabwe. This chapter's objective is to draw conclusions on the development of the framework for the adoption mobile ERP system. Recommendations on what is the best framework for the adoption of cloud based ERP system in transport business sector.

### **5.2 Re-statement of the research problem and objectives**

Lack of proper framework for the adoption of cloud based ERP systems in transport business sector in Zimbabwe, despite numerous benefits that can be achieved through the use of cloud based ERP systems. Cloud based ERP system will bring hope in the way transactions are being handled in the transport business sector. In the transport business sector in Zimbabwe there is no written down framework for the implementation of cloud based ERP systems, resulting in failing to properly implement cloud based ERP.

### **5.3 Answering the major question**

As evidenced everything gathered from interviews as well as questionnaires through the participants, there is need to come up with a proposed framework for the implementation of cloud based Enterprise Resource Planning (ERP) system in the transport business sector in Zimbabwe.

#### **5.3.1 Proposed Cloud Based ERP Framework for transport business sector**

The proposed framework has got 8 main parts which includes Present Situation Analysis, Problem and Business Process Detection, Developing New Process, Information System Incorporation, Organizing System Training, Application, Process Improvement and ERP System Delivery.

Each stage consist of individual, corporate and Strategic issues which should be put in place in order to successful implement cloud based ERP system.

Figure 5.1: Proposed cloud based ERP framework

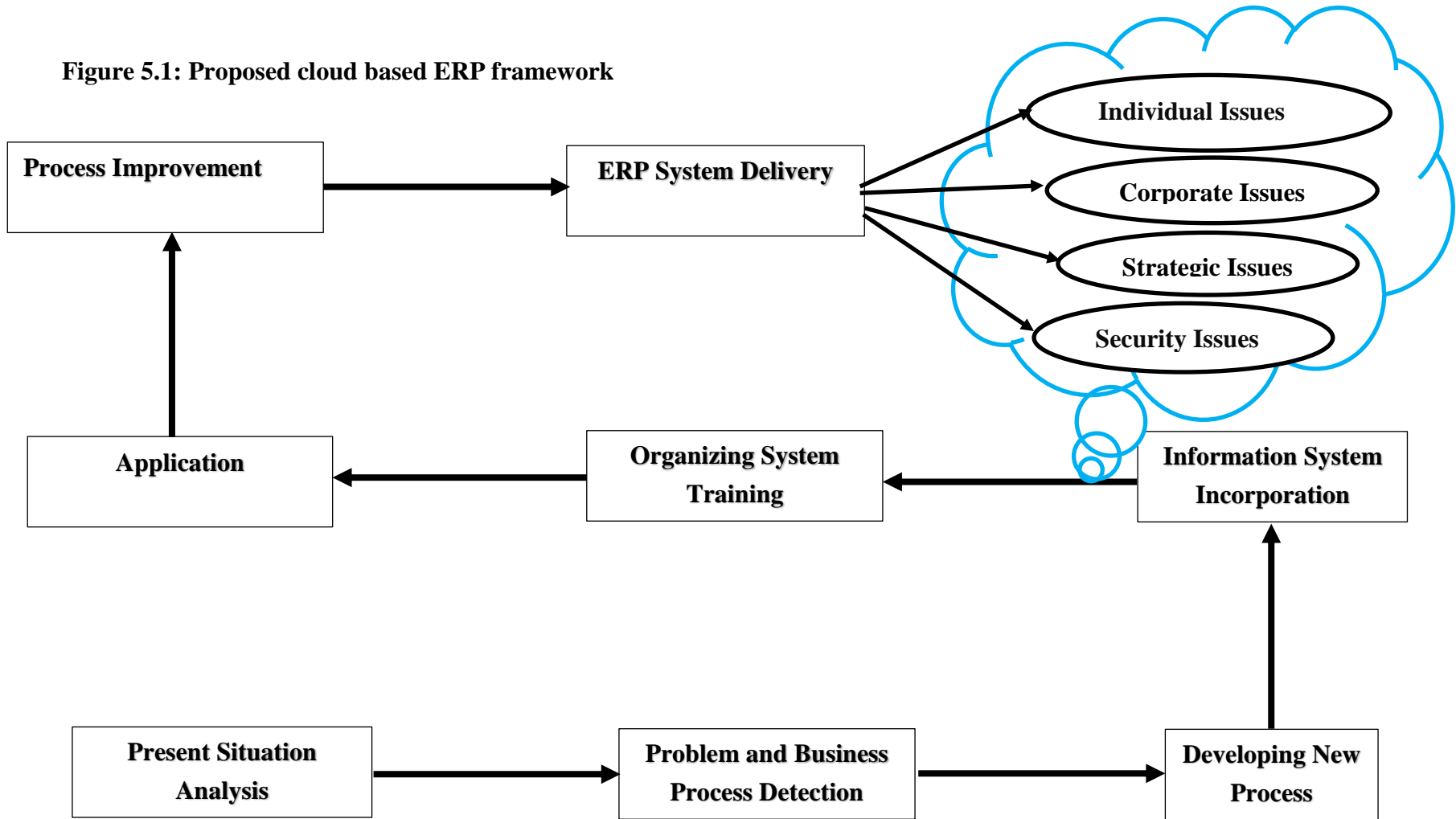

An effective cloud based Enterprise Resource Planning (ERP) system adoption needs appropriate executive involvements. The proposed cloud based ERP system implementation framework will touch on a number of areas which contribute to influencing transport business sector to achieve high performance. Transport industry is the hub of all business activities so if the transport system is good all other business functions will perform well thereby achieve high performance.

The proposed cloud based ERP system implementation framework should help the management understand the requirements and help the project team to get management trust, commitment and support. In order to achieve management trust, commitment and support there are three issues that needs to be addressed: individual, corporate and strategy issues. These issues will be explained in detail as follows:

### **Strategy Issues**

Executive as well as Non-Executive management should provide resources for the successful implementation of the cloud based Enterprise Resource Planning (ERP) system, failure to get their trust, commitment and funding, the organisation will fail to successful adopt new system. All the required resources has to be provided by the top management as well as the leadership for the cloud based ERP implementation. Top management is there to give clear direction on ERP implementation, staff development and their part cover up to the post- adoption phase of the framework. Clear strategy for cloud based Enterprise Resource Planning (ERP) system adoption and strong objectives (achievable of cause) should be put in place. Procedures should be visibly redesigned in advance and the implementation approach has to be in sequence, bulk of the work force has to be developed, and the changeover procedure should be in way that allows the company to save time and money.

### **Security Issues**

When putting your data on the cloud there is need to have clear strategies and put appropriate security mechanisms in place to protect the data. Usually the service provider will carter for the security of your data but there is need to have a clear Service level Agreement (SLA) so that the organization's data is protected in case of eventualities happen to the data. Security is very important especially when dealing with sensitive information like in this case study of CMED (Pvt) Ltd nature. So there is need to carefully select the best vendor with a good reputation



otherwise information of national security will end up in wrong hands and affect the security of the country.

### **Individual Issues**

Systems operators should be part of the team from the beginning of the cloud based ERP systems development by take part in the system designing and all the processes, involving them in defining of information needs and requirements and the project team should collect operators' thoughts concerning the Enterprise Resource Planning (ERP) system. Resistance to change from employees should be dealt by at the initial stages of the Enterprise Resource Planning (ERP) project adoption as lack of awareness and understanding the purpose of the cloud based ERP system employees will tend to resist its implementation. If people get enough training and top management support about the ERP system their attitude will change. Education and staff development regarding the cloud based ERP system should start at the start of the adoption to majority of the workforce and staff development should include in what way the ERP will be used and in what way the business process will be changed due to the implementation of cloud based ERP system. System manuals must be available for users to have point of reference when faced with challenges.

Employee as well as customers and suppliers personal information have to be protected. As the data is migrated to cloud there is need to properly define access level so that each user will have access to information relevant to his or her line of duties to avoid conflict of interest and leaking of sensitive information. Appropriate audit trails should be put in place in order to be able to trace who accessed what, when, how and for what reason?

### **Corporate Issues**

Project team should be established at the beginning of the project and the project manager should be the best employee, with a better understanding of what needs to be achieved and a track record (experience and knowledge) of good achievements. The project team must be given responsibility and have a clearly defined project plan. It is well known that cloud based ERP system will result in the reengineering of corporate procedures, so the corporate procedures should be analyzed to detect the possible changes needed for reengineering. Employee should be empowered, get employee involvement in training and education that will help in changing the

culture of the organisation. The chain of command and communication should be followed throughout the stages of the proposed framework. To successful implementation of the cloud based ERP system there is need to have relevant qualified and experienced employees, because both the Information Technology and computer skills are helpful for cloud based ERP system implementation.

All the other stages are the same like those for general frameworks the only deference comes when the data is now being put on the cloud. When data is stored on the cloud there is high risk of losing corporate secrets to the competitors, so there is need to put appropriate mechanisms to protect that information.

#### 5.4 Recommendations

The following were identified as the recommendations for addressing challenges and problems in the implementation of ERP:

- Adequate time should be allocated to the project management team for ERP system implementation.
- Enough resources should be provided to allow good implementation of the ERP system.
- Management of change should be headed by the project management team.

**Table 5.1: Recommendations from findings**

<b>Finding</b>	<b>Recommendation</b>
Time Constraints	There is need to allocate enough time for the cloud based ERP system implementation.
Lack of qualified personnel	There is need to engage people with appropriate qualifications to take charge of the cloud based ERP system project.
Lack of top management support	Top management must be engaged at the early stages and should form part of the commit to spearhead the project. (Involve top management from the beginning). Let them give their inputs so that the will trust and support the project.

Resource allocation issues	The issue of resource allocation is always a problem if the top management is not supporting the project, mostly they will try to limit the resources because they will not trust the vision. More resources must be availed.
Change Management	There is need to put in place a team of change management experts that will be assigned to deal with change issues from the beginning of the project to deal with resistance to change.
Training of users	There is need to allocate adequate time for the training of users so that they understand the system. Trainers should be people who are people oriented know that people have different level of understanding.

### 5.5 Suggestion for Future Research

There is still need for future research because there are other dimensions that need to be explored, although this research achieved its objectives. In the area of transport business in Zimbabwe there is need to strategize in order to survive in the long run. The strategy has to take into consideration all the factors that contribute in the survival of the organisation among the industry competitiveness. The field of information technology is so dynamic that things are changing every day. So future research can touch on the speed of accessing data stored on the cloud and the storage capacity of the cloud. Cloud stored data encryption is another area for future research, hoe the cloud stored data can be encrypted and decrypted. The framework can further be modified to incorporate the issue of data encryption concepts.

### 5.6 Conclusion

The cloud based ERP system Framework was developed to assist transport organisation in implementing cloud based ERP systems. Cloud based ERP systems help organisations to cut costs in terms hardware, software and upgrades as well as reduce up-front expenses. With cloud based ERP systems the organisation will improve on accessibility, mobility and usability. Moving into the cloud based ERP system is very beneficial and improved system availability and disaster recovery.

## Reference

1. Acumatica (2015) accessed on <http://www.acumatica.com/8-great-erp-prediction-lists/> 25/01/2016
2. Adam, F., and O' Doherty, P. (2000). *Lesson from enterprise resource planning implementations in Ireland – towards smaller and shorter ERP projects*. *Journal of Information Technology (Routledge, Ltd.)* 15(4), 305-316.
3. Ahmed A. Elragal and Ayman M. Al-Serafi. (2011). The Effect of ERP System Implementation on Business Performance: An Exploratory Case-Study. *Communications of the IBIMA*, Vol. 2011, Article ID. 670212.
4. Al- Mashari, M., (2003). Implementation ERP through SAP R/3: A Process Change Management (PCM) Perspective. *J. King Saud University*, 14, 25-35.
5. Aladwani, A. M., (2001). Change Management Strategies for Successful ERP Implementation. *Business Process Journal*, 7(3), 266-275.
6. Al-Mashari, M and Zairi, M. (2000a). Supply-chain re-engineering using enterprise-resource planning (ERP) systems: an analysis of a SAP R/3 implementation case. *International Journal of Physical Distribution & Logistics Management*, Vol. 30 No. 3/4, pp. 296-313.
7. Al-Mashari, M. (2003). Enterprise Resource Planning (ERP) Systems: a research agenda. *Industrial Management & Data Systems*, Vol. 103 No. 1, pp. 22-7.
8. Al-Mashari, M. and Zairi, M. (2000). Information and business process equality: the case of SAP R/3 implementation, *Electronic Journal on Information Systems in Developing Countries*, Vol. 2
9. Al-Mashari, M. and Zairi, M. (2000b). The effective application of SAP R/3: a proposed model of best practice. *Logistics Information Management*, Vol. 13 No. 3, pp. 156-66.
10. Al-Mashari, M., (2003). A process change oriented Model for ERP Applications, *International Journal of Human-computer Interaction*, 16, 1, pp.39-55.
11. Al-Mashari, M., Zairi, M., & Okazawa, K. (2006). Enterprise Resource Planning (ERP) implementation: a useful road map. *International Journal of Management and Enterprise Development*, 3(1/2), 169-180.
12. Aloini, B., Bozarth C., Van De Ven, A., (2007). ERP implementation efforts at three firms: integrating lessons from the SISP and IT enabled change literature. *College of*

- Management, Northern Carolina State University, Raleigh North Carolina, USA. Vol 26, issue 11.
13. Amoako-Gyampah, K. (2007). ERP implementation factors: A comparison of managerial and end-user perspectives, *Business Process & Management Journal*, 10(2), pp. 171-183. Reprinted in *Journal of Enterprise Resource Management*, 20, 2007.
  14. Baktashmotlagh. M, Bigdeli. A and Lovell. B. C. (2011). Dynamic Resource Aware Sensor Networks: Integration of Sensor Cloud and ERPs. *8th IEEE International Conference on Advanced Video and Signal Based Surveillance*, pp. 455-460.
  15. Beiske, B, 2007, *Research Methods: Uses and Limitations of questionnaires, interviews and case studies*, GRIN Verlag
  16. Blackstone Jr., J.H., Cox, J.F., 2005. *APICS Dictionary*, 11th ed. APICS: The Association for Operations Management.
  17. Bradford, M., Florin, J. (2003). Examining the Role of Innovation Diffusion Factors on the Implementation Success of Enterprise Resource Planning Systems. *International Journal of Accounting Information Systems*.
  18. Dimitrios, M., Dimitrios, C., Charalampos, T., (2010). Factors affecting ERP system implementation effectiveness. *Journal of Enterprise Information Management*. Vol. 25, Issue 1. Pp.60-68.
  19. Galani. D, Gravas. E and Stavropoulos. A. (2010).The Impact of ERP Systems on Accounting Process. *World Academy of Science, Engineering and Technology*, Vol. 66, pp. 418-423.
  20. Gallagher, K. P., Gallagher, V., C., (2012). Organizing for post implementation ERP: A contingency theory perspective. Department of Business informatics, Northern Kentucky University, Highlands Heights, Kentucky USA. Vol 25, issue 2,
  21. Garvin D.A, and Roberto, M.A. (2005).Change Through Persuasion. *Harvard Business Review*. [Online]. [Accessed, 12 April 2016].
  22. Gulati, P. M, 2009, *Research Management: Fundamental and Applied Research*, Global India Publications
  23. Hawkins, K. (2004). `User involvement, ease of use, perceived usefulness, and behavioral intention: a test of the enhanced TAM in ERP implementation environment, 30th DSI Proceedings, 20-23 November, pp. 805-7.

24. Hong, E., Kim, C., (2007). Improving enterprise resource planning (ERP) fit to organisational process through knowledge transfer, *International Journal of Information Management*, Vol. 27, pp. 200-12.
25. <http://www.businessdictionary.com/definition/data-collection.html#ixzz48SRLj0Us> accessed on 12/05/2016
26. Huang H., Thong, J.Y.L. Chen, J.-R. (2004). Resource constraints and information systems implementation in Singaporean small businesses, *Omega*, Vol. 29 No. 2, pp. 143-56.
27. Isse. J (2010). *Cloud Computing and the Innovation Process of Technology Consulting Services: the Case of Accenture*. Master Thesis, Blekinge Institute of Technology.
28. Jorgensen, H.H., Owen, L. & Neus, A. (2009). Strategy and Leadership. [Special Issue]. Stop improvising change management. 37(38-44).
29. Kale. P.T, Banwait. S.S, and Laroiya. S.C (2008). Enterprise Resource Planning Implementation in Indian SMEs: Issues and Challenges. *12th Annual International Conference of Society of Operation Management*, pp. 242-248.
30. Kemp, M.J., Low, G.C. (2008). ERP innovation implementation model incorporating change management, *Business Process Management Journal*, Vol. 14 Issue: 2, pp.228 - 242.
31. Kotter, J. P. (1995). *Leading Change*. USA. Harvard Business School Press.
32. Kumar, V., Maheshwari, B., & Kumar, U. (2002). Enterprise resource systems adopting process: a survey of Canadian organizations. *International Journal of Production Research*, 40(3), 509-523.
33. Lee, H., and Lee, J., (2004). The theory and Practice Breakthrough IT change management.
34. Marnewick, C. & Labuschagne, L. (2006). A structured approach to derive projects from the organisational vision. Paper delivered at PMI Research Conference 2006: New Directions in Project Management.
35. McAdam, D., Galloway P. (2007). An exploratory study of alignment ERP implementation and organisational development activities in a newly established firm, *Journal of Enterprise Information Management*, Vol. 22 No. 3, pp. 298-316.
36. McCarthy, C., Eastman, D., (2010). Change Management Strategies for an

- effective EMR Implementation. Ohio, Chicago. HMS Publishers.
37. Mcleod, S. A. (2014). Sampling Methods. Retrieved from [www.simplypsychology.org/sampling.html](http://www.simplypsychology.org/sampling.html)
  38. Millis, K., & Merken, R., (2008). Success factors regarding the implementation of ICT investment projects. *Internal Journal of Production. Economics*, 80, 105-117.
  39. Nah, F., Lau, K and Kuang, Z. (2001). Critical Factors for Successful Implementation of Enterprise System. *Business Process Management*, 7(3), pp. 285-293.
  40. Pansiri, J., (2005). The influence of Manager's characteristics and perceptions in strategic change. *School of Business. Volume 43, Issue 9. The Harvard Business Review*.
  41. Pelissier, R. (2008) "Business Research Made Easy" Juta & Co.
  42. Saleem. R (2011). *Cloud Computing Effect On Enterprises in term of cost and security*, Mater Thesis, Lund University.
  43. Saunders. M, Lewis. P, and Thornhill. A, (2009) *Research Methods for Business Students, 5<sup>th</sup> Edition, Harlow: Pearson Education*.
  44. Schiavone, F. (2012). Resistance to change as a positive influencer: an introduction journal of organisational change management. Vol 25. Issue 6, published 2012, pp.784-797.
  45. Senge, P., M. (2010). *The Fifth Discipline: The Art & Practice of the Learning Organisations*. London: Century Business
  46. Shang, S. and Seddon, P.B. *Assessing and Managing the benefits of enterprise systems: the business manager's perspective. Information Systems Journal*, 2002; 12: 271-299
  47. Sharon B. Merriam, *Qualitative Research: A Guide to Design and Implementation*. John Wiley & Sons, 2009.
  48. Shin, H., (2008). A process model of application software package acquisition and implementation, *Journal of System Software*, Vol. 32 No. 1, pp. 57-64.
  49. Shkwskil. S. and Sabel'mkova. E. (2011). *Resource-control System based on the ERP system Coke and Chemistry*, 54(11), pp 426-427
  50. Snieder, R & Larner, K, 2009, *The Art of Being a Scientist: A Guide for Graduate Students and their Mentors*, Cambridge University Press

51. Somers, T., Nelson, K., & Ragowsky, A. 2000. Enterprise Resource Planning ERP for the Next Millenium: Development of an Integrative Framework and Implications for Research. *In: Proceedings of Americas Conference on Information Systems AMCIS*.
52. Stratman, J., K., (2009). Realizing benefits from enterprise resource planning. Working paper. College of Management, Georgia Institute of Technology.
53. Tansley, C., Turner, P., Carley, F., Harris, L., Sempik, A., Stewart, J. (2007). *Talent: Strategy, management, measurement*.
54. Toni M. Somers and Klara Nelson. (2001). London: Chartered Institute of Personnel and Development (CIPD). The Impact of Critical Success Factors across the Stages of Enterprise Resource Planning Implementations. *Proceedings of the 34th Hawaii International Conference on System Sciences*, pp. 8016, Vol. 8
55. Tsai, W. H., Chen, S. P., Hwang, E. T., & Hsu, J. L. (2010). *A study of the impact of business process on the ERP system effectiveness. International Journal of Business and Management*, 5(9), 26-37.
56. Umble, E.J., Umble, M.M. (2003). Enterprise resource planning: implementation Procedures and critical success factors, *European Journal of Operations Research*, Vol. 146, pp. 241-57.
57. Vimalkummar. P. (2012). *Implemetation of ERP in Business Process Based on Cloud Computing IOSR Journal of Business and Management*, 3(11), pp45-50.
58. Williams, M., D., & Williams, J., (2007). A change management approach to evaluating ICT investment initiatives. *Journal of Enterprise Information Management*, 20, 32-50.
59. Worley S., Sambamurthy, V. and Kirsch, L.J. (2005). An integrative framework of the information systems development process, *Decision Sciences*, Vol. 31 No. 2, pp. 391-411.
60. Yao. X and Dan-Rognlie. M.B, (2007). Distributed Transaction Management in SOA-based System Integration. Mater Thesis, IT University of Copenhagen
61. Yaseen. S.G, (2009). Critical Factors Affecting Enterprise Resource Planning Implementation: An Explanatory Case Study. *International Journal of Computer Science and Network Security IJCSNS*, Vol. 9, No. 4, pp. 359-363.
62. Yin, Robert K: Case Study Research. Design and Methods. Sage Publications, Thousand Oaks, 4<sup>th</sup> Edition. 2009.



63. Yin. R.K. (2003) *Case Study Research, Design, and Method Third Edition*, Sage Publications, USA.
64. Zhang, K., Lee, A. and Zhang, Z. (2007). Critical Success Factors of Enterprise Resource Planning Systems Implementation Success in China. Proceeding of the 36th Hawaii International Conference on System Sciences, pp. 61-75.

## **APPENDICES**

### **APPENDIX A - INTERVIEW GUIDE**

#### **Interview Questions.**

1. Are you using an ERP system?
2. What device are you using to access the ERP system?
3. How often does your ERP system upgraded?
4. Does your suppliers get reorder level records from the ERP system?
5. Does your customers get information about new products from the ERP system?
6. How do you communicate with your suppliers and customers?
7. Does the ERP system help in Customer profiling?
8. How do you use ERP system to enhance your customer service?
9. Do you have an online payment facility that is linked to the ERP system?
10. What ERP technologies do you use at your company?
11. Does the ERP system allow the sending of tailor e-mails to customers?
12. Do the ERP system allow customers to post feedback after service delivery?
13. How do you use and keep feedback from customers received through ERP system?
14. Does ERP system help to generate daily, monthly and or yearly reports?
15. How long does it take to generate consolidated reports using ERP system?
16. What challenges are you facing in the using ERP system?

## **APPENDIX B –SAMPLE QUESTIONNAIRE**

Dear Respondent,

I Bindi Maxwell a Masters in Information Systems Management student at Midlands State University and I am conducting a study of implementation of cloud based Enterprise Resource planning (ERP) in the transport business sector in Zimbabwe. The objective of this research is to develop the framework for the implementation of operational cloud based ERP for transport industry in Zimbabwe. Through your participation, I eventually hope to understand how best to come up with the framework.

Enclosed with this letter is a brief questionnaire that asks a variety of questions about your ERP system. I am asking you to look over the questionnaire and, if you choose to do so, complete the questionnaire and give it back to me as soon as you completed the questionnaire.

If you choose to participate, do not write your name on the questionnaire for anonymity and confidentiality. Your responses will not be identified with you personally, nor will anyone be able to determine which company you work for, the results will be reported in aggregate. Nothing you say on the questionnaire will in any way influence your present or future employment with your company. Your participation is voluntary and there is no penalty if you do not participate. Your participation is greatly appreciated since this research will add to the development of a framework for the implementation of cloud based ERP systems for the transport business sector in Zimbabwe and that framework will leave forever.

If you have any questions or concerns about completing the questionnaire or about participating in this study, you may contact me on +263 712 325 482 or email at [mbindim@gmail.com](mailto:mbindim@gmail.com). If you have any questions about your rights as a research subject, you may contact my Supervisors Mrs. A.N Mutembedza at [mavungaa@msu.ac.zw](mailto:mavungaa@msu.ac.zw) and Mr. M. Zhou at [zhoum@msu.ac.zw](mailto:zhoum@msu.ac.zw).

Sincerely,

**Maxwell Bindi**

*Please fill in the details appropriately. Tick the most suitable answer where boxes are provided*

**Section A: Demographic.**

1. At what level do you work?

- Executive
- Management
- Foreman
- Supervisor
- Staff

2. I identify my Gender as ...

- Male
- Female
- Transgender

3. Highest level of education

- Certificate/Diploma
- BA/BSc Degree/BCom/BTech
- Masters
- PhD
- Postgraduate diploma

4. How old are you? (Age range)

- Younger than 20 years
- 20 – 29 years
- 30 – 39 years
- 40 – 49 years
- 50 years or older

5. What is your employment type?

- Contract
- Permanent
- Part-time
- Apprentice
- Student

6. For how long have you been working in your organisation?

Less than 1 year

1 – 3 years

4 – 8 years

9 – 12 years

13 – 20 years

21 years or more

### **Section B: Enterprise Resource Planning (ERP) implementation**

An Enterprise Resource Planning (ERP) system is an enterprise-wide software system that provides comprehensive functionality and allows integration of core business processes in organisations (Hawking et al, 2004; Klaus et al 2000; Scholtz et al 2013). For example fleet management, tyre management, fuel management, finance management, inventory management to name but just a few. The key to understanding ERP software is to think “integration.” ERP software links systems across an enterprise to streamline workflow, share information among different departments, and provide insight into transport business sector’s operations (Berry, 2016). Enterprise Resources Planning (ERP) systems are enterprise-wide information system packages, which consist of a comprehensive set of software modules that aim to support and integrate all key business processes across various functional divisions of an organisation by using a single data repository (Shang and Seddon, 2002). ERP is an enterprise-wide information system designed to coordinate all the resources, information and activities needed to complete business processes such as order fulfilment and billing.

7. For how long have you been using On-Premises ERP (Enterprise Resource Planning) system?

3 – 6 months

7 -11 months

1 – 3 years

More than 3 years

Never used

8. Can you please outline the operations of On-Premises ERP system that you are using?

- Personnel Management
- Inventory Management
- Finance Management
- Corporate Governance
- Fleet Management
- Workshop Management
- E-Ticketing/E-booking
- Sales and Marketing Management
- Billing and Telematics.

9. Do you think there is need for improvements to the current ERP system modules?

- Yes                       No

10. If your answer is yes, can you please give suggestions on improvements:

.....  
.....  
.....  
.....

11. What do you understand by the term ERP system?

.....  
.....  
.....  
.....  
.....

12. What is your view on cloud based ERP system as an alternative to the On-Premises ERP system?

.....  
.....  
.....

13. What impact do you think cloud based ERP system will have on the convenience in providing services to customers?

.....  
.....

14. How else do you think the On-Premises ERP system could be improved?

.....  
.....

15. How does it feel to use ERP system in CMED (Pvt) Ltd today, any benefits?

.....  
.....  
.....

16. What were the reasons for introducing ERP system?

.....  
.....  
.....

17. Looking at the implementation of ERP system, do you have any regrets, or do you think it was the right decision, and why?

.....  
.....  
.....

18. What would you say are the progress and success factors in the implementation of the ERP system?

.....  
.....  
.....

19. What are some of the challenges or problems faced in the implementation of an ERP system? How are these problems or challenges affecting your company?

.....  
.....  
.....

20. What do you think could be done to address these challenges? Who should play a role on addressing these challenges/problems?

.....  
.....  
.....

**Section C: Training of employees**

21. What type(s) of training did you receive?

- Project team training
- End user training
- Traditional training
- Web-based training
- Did not receive training.

Others please specify:

22. If you receive training, how long does it take you to master the systems?

- Master in a week
- Master in a month
- Master in 3 months
- Master in 6 months
- Still receiving training
- Did not mastered

**Section D: Security issues associated with ERP implementation**

23. What security problems are you experiencing with On-Premises ERP system? (Tick all

Appropriate)

- Unauthorised Access
- Denial of Service (DoS)
- Viruses
- Breach of security policies
- ERP system abuse



24. How often do you change your password?

- Every week
- Every two weeks
- Every month
- Every 2 months
- Do not change the password at all

25. What are the required combinations for your passwords?

- At least one capital letter
- At least be eight characters in length
- At least one special character
- At least one small letter
- At least have a number

Thank you for your time